

TIMBRE, TEXTURE AND SPIRITUAL SYMBOLISM  
IN GUBAIDULINA'S TWO WORKS  
*DE PROFUNDIS* AND *ET EXSPECTO*

Aural Sonology as a tool to explore sonic and structural aspects of interpretation  
in contemporary accordion music

Andreas Nikolai Angell

Master thesis in applied music theory

May 15, 2017



**Norges  
musikkhøgskole**  
Norwegian Academy  
of Music

### **Abstract**

This thesis concerns multiple aural analyses of the pieces for accordion by Sofia Gubaidulina; *De Profundis* and *Et Exspecto*. Through aural sonology, this research focuses on the exploration of emerging gestalts through performance and interpretation. Unlike a traditional analysis of the music manifested in the score, this approach concerns sonic and structural elements that are heard through the recorded performance.

Gubaidulina is considered as one of the leading avant-garde personalities that entered the creative scene in the early 1960s, during the isolation of the «Iron Curtain» in the Soviet Union.

As a professed orthodox Christian, Gubaidulina is recognized for using religious symbolism in her music.

The goal of this thesis is to ascertain which timbral musical objects are heard, illuminate the structural forms of the music and make an interpretation of the symbolic meaning in the chosen works.

If the reader is interested in seeing the aural analyses, they can use the following link:

<http://bit.ly/2prw7y4>

## **Acknowledgements**

I would like to thank my supervisor Lasse Thoresen, who always helped me whenever I ran into a trouble spot or had a question about my research. He consistently allowed this paper to be my own work, but steered me in the right direction whenever he thought I needed it.

Thank you, Live, for invaluable support during this project in all possible manners, both intrinsic and extrinsic to the thesis.

## **Preface**

I first heard Sofia Gubaidulina in a high school performance by an older student at the conservatory in Oslo and I have been fascinated with it ever since. This was the original reason that I chose her music for my research.

The experience of listening to Gubaidulina's music made a strong impression on me due the radical sounds which were so different from more traditional repertoire that I was used to hearing for my instrument, the accordion. The timbre was almost unrecognizable to my ear at that time. The spiritual quality of Gubaidulina's music has a major appeal for me and her music often results in achieving a state of transcendental serenity, after long, complex struggles. Her works reveal a passionate, emotional dimension filled with layers of messages and mystic symbolism that are hidden within the music.

# Contents

## 1 Introduction

1.1 Explorations and intensions.....	1
1.2 Two works for accordion.....	2
1.3 Introducing Gubaidulina.....	2
1.4 Research questions.....	3

## 2 The spiritual world of Sofia Gubaidulina

2.1 Observation of available biographical sources.....	5
2.2 Early years.....	5
2.3 Later years.....	8
2.4 Meeting Friedrich Lips.....	9
2.5 Symbolism.....	10
2.6 Dichotomy.....	12
2.7 Transfiguration.....	13

## 3 Method part I

3.1 Clarifications.....	14
3.2 Aural Sonology.....	14
3.3 Terminology.....	17
3.3.1 Spectromorphology - level one.....	17
3.2.2 Endosemantic analysis of harmonicity (harmonic colors) - level two.....	19
3.2.3 Time fields - level three.....	23
3.2.4 Dynamic form - level three.....	26

## 4 De Profundis

4.1 Geir Draugsvoll.....	31
4.2 Aural analysis of <i>De Profundis</i> .....	31
4.3 Form structures - The fundamental synopsis of the piece.....	45
4.4 Introduction to exosemiotics as-heard.....	50
4.5 Sound-objects, harmonicities and dynamic forms.....	51
4.6 Exosemantic indications .....	52
4.7 Psalm 130 .....	52
4.8 Exosemiotic analysis of <i>De Profundis</i> .....	54

4.9 Conclusion regarding the semiotic interpretation.....	62
4.10 <i>De Profundis</i> (Geir Draugsvoll): Signified indications and fields.....	63

## 5 Method part II

5.1 Terminology.....	64
5.2 Melodic fragments - level two.....	64
5.3 Flux - level two.....	66
5.4 Enfold versus unfold - level two.....	67
5.5 Concord versus discord - level two.....	68
5.6 Form-building processes and form-building transformations - level three.....	69
5.6.1 Form-building processes.....	69
5.6.2 Typology of form-building elements.....	70
5.6.3 Defining textures.....	72

## 6 Et Exspecto

6.1 Iñaki Alberdi.....	74
6.2 The title.....	75
6.3. Aural Analyses: 1st movement - opening.....	76
6.4. Aural Analyses: 1st movement - ending.....	80
6.5. Aural analyses: 2nd movement - opening.....	84
6.6. Aural analyses: 3rd movement - opening.....	89
6.7. Aural analyses: 4th movement - opening.....	94
6.8. Aural analyses: 4th movement - ending.....	98
6.9. Aural analyses: 5th movement - Whole.....	101

## 7 Critical Reflections

7.1 Introduction.....	114
7.2 Summary of my research.....	114
7.3 Expanding sonology.....	116
7.4 Intension of this artistic research.....	117
7.5 A look in to other publications .....	117
7.6 Last words.....	121

# 1 Introduction

## 1.1 Explorations and intentions

In this publication I wish to present multiple aural analyses of the pieces for accordion by Sofia Gubaidulina; *De Profundis* and *Et Exspecto*. Moreover, I will present a brief biographical perspective of the composer, by limiting the study to her early life to the point where she wrote the selected works, as well as approaching her spiritual world and beliefs, and conclude with a critical reflection of my research.

My goal of this thesis is to ascertain which timbral musical objects are heard, illuminate the structural forms of the music and make an interpretation of the symbolic meaning in the chosen works.

I will use the method of aural sonology by Lasse Thoresen, which centers on the intentions of reductive and taxonomic listening, meaning the consideration of the sound itself, and the sound patterns, i.e., the integration into greater entities. The knowledge attained by these listening intentions of the chosen performances, will occur in the details of the aural analyses and will provide knowledge concerning aural gestalt principles.

This research focuses on the exploration of emerging gestalts through performances and interpretations of the selected works by Gubaidulina. Unlike a traditional analysis of the music manifested in the score, this approach concerns sonic and structural elements that are heard through the recorded performance. The center of analysis is the interpretation by the performer, who creates and structures the music as it is perceived.

The aural analysis of *De Profundis* will be executed through the performance of Geir Draugsvoll, and will consist of a comprehensive analysis of the interpretation and the music as a whole. The analysis will involve a consideration of endosemantic indications and relations of sound-objects, sound-patterns and form-building gestalts. These indications will further be the subject for an exosemantic interpretation of meaning and spiritual symbolism.

The aural analyses of *Et Exspecto* will be executed through the use of different performances, as I wish to compare interpretations with each other. Instead of a comprehensive analysis of the work, I will focus on selected parts of each movement and analyze two different interpretations of the same material. I will present analyses of four different interpretations, performed by Friedrich Lips, Geir Draugsvoll, Iñaki Alberdi and myself. This departure establishes

an intriguing exploration on how different sonic and structural dimensions emerges through different performances, and how it may establish different symbolic meanings.

## 1.2 Two works for accordion

The selected works, *De Profundis* (1978) and *Sonate: Et Exspecto* (1985) stand as important pieces in the accordion literature. Since the first performance of the pieces in Moscow in 1980 and 1987 by Friedrich Lips, the pieces are regularly performed and recorded around the world, producing new interpretations from both professionals and conservatory-students.<sup>1</sup>

*De Profundis*, is a one-movement work, where the title ('out of the depths') is a reference to Psalm 130, which starts with the first line 'Out of the depths I cry to you, Lord' ('De profundis clamavi ad te, Domine').

*Sonate: Et exspecto* (often referred to as *Et Exspecto*), is a five-movement work, where the title ('I expect') refers to the second last line of the Nicene Creed which is translated as 'I look for the resurrection of the dead' ('Et exspecto resurrectionem mortuorum').

Gubaidulina's alteration of the traditional sounds from the accordion, frequently known through Russian-folk music, went to the point that it became unrecognizable as an instrument. The timbral explorations in the selected works became an important innovation for the accordion as a modern instrument, as well as a great inspiration for contemporary music to come.

## 1.3 Introducing Gubaidulina

Sofia Gubaidulina has become one of the most acknowledged composers of our time, after earning recognition in the West since the early 1980s. She is considered, along with Alfred Schnittke and Edison Denisov, as one of the leading avant-garde personalities that entered the creative scene in early 1960s, during the isolation of the «Iron Curtain» in the Soviet Union. The ideals of this generation were characterized by the quest for truth, rebellion, independent creative curiosity and the urge to break out to the other side of the world.

In the case of Gubaidulina, she was a carrier of many featured taboos; not only as a woman amongst mostly male composers, but also as a practicing believer of Christianity in an atheistic Soviet Union. Furthermore, she had to fight oppression and exclusion, being a person of mixed Tatar-Russian background in a broadly xenophobic culture and as member of maverick, partisan

---

<sup>1</sup> Premiere dates collected from:  
Kevin Friedrich, «Interview of Friedrich Lips», (*Accordions Worldwide*, 1999)  
<http://www.accordions.com/interviews/lips/lips2.shtml>.



artistic groups in society of cultural suppression.<sup>2</sup> Being treated as an «outsider» was perhaps benefiting, as it is likely one of the reasons that led to her creating her own personal, distinctive style.

As a professed orthodox Christian, Gubaidulina is recognized for using religious symbolism in her music. Titles like *In Croce*, *Sieben Worte*, *Hell und Dunkel*, along with the selected works represented in this thesis, *De Profundis* and *Et Exspecto*, are examples of descriptions referring to religious themes such as light and darkness, the cross, the apocalypse and the last judgment.

Additionally, the qualities that have earned her artistic recognition are her unusual explorations of sounds, exquisite orchestration and instrumentation, subtle use of textural-colors, balance in structures and form, and the connection of these together with a presence of mysticism through dramaturgical contents in the music.<sup>3</sup>

#### **1.4 Research questions**

The process of exploring timbre, texture and spiritual symbolism in this context, is outlined by several important research questions which I wish to ask.

- *What define the sonic and structural elements of the selected works?*

Thoresen provides a broad selection of different methods in analyzing music as heard, and I wish to acquire many of these, as it seems that sonic and structural elements naturally emerge through these considerations. I do not intend to deconstruct the musical structure through the description of a method that doesn't seem to emerge itself through the music. I argue, that all applied methods of analyses in my thesis, are suitable to articulate a certain knowledge that already exists in the sounding music. The applied methods used in my analyses are spectromorphology (analysis of sound-objects), flux, enfold/unfold, discord/concord (analysis of sound-patterns) and time-fields, dynamic form, form-building processes and form-building elements (analysis of form-building gestalts).<sup>4</sup> I further intend to present two original concepts of analyzing sound-patterns, which are the consideration of harmonic color and melodic fragmentation.

- *What knowledge differentiates a musical performance from the written score?*

---

<sup>2</sup> Ivana Medić, «Gubaidulina, misunderstood», (The Open University United Kingdom, 2012), 101.

<sup>3</sup> Young-Mi Lee, *Musical contents and symbolic interpretation in Sofia Gubaidulina's «Two Paths: a dedication to Mary and Martha*, (School of The Ohio State University, 2007), 1.

<sup>4</sup> Lasse Thoresen, *Emergent Musical Forms: Aural Explorations*. Studies in Music of the (University of Western Ontario, 2015).

My understanding is that most musicologists, historians and classical performers would argue that the written score is possibly the most important source of knowledge, concerning compositional apprehension and aesthetics. While I don't necessarily disagree, I still argue that a significant amount of knowledge concerning the interpretive qualities of the music are lacking when the score is exclusively studied. My aim is to clarify some of these qualities that solely exists in the sounding music.

- *How can sonic and structural elements be used to interpret musical semiotics?*

Symbolic elements are certainly appointed to these pieces as both titles refers to a specific spiritual context. I will appoint exosemantic interpretations of musical elements that appear as a dichotomy, meaning a division of two mutually exclusive, opposed or contradictory groups. The use of dichotomies in sound-elements is a central part of Gubaidulina's music and symbolic indications. This could be a cluster, which could be associated with 'fear', opposed to a major-chord, which could be associated with 'hope'. I will also interpret the symbolic indications of transfiguration. These are sound-objects, patterns and structural elements that transforms to a different state, such as the glissandi, which could be associated with 'transcendence'.

- *What do you learn as a performer?*

The study of musical interpretation as an articulated subject of analysis, as well as that of other art forms involving embodied knowledge, is a challenging discourse in academic research. This question centers on the most essential purpose of my aural analyses; not only as a method for artistic research, but as a beneficial tool of studying established interpretations. The extensive interpretive qualities of the selected works have been explored by many performers since its premiere by Friedrich Lips. The method of aural sonology provides a certain terminology to achieve a deeper understanding of how the performer is using sonic and structural elements in the music.

## 2 The spiritual world of Sofia Gubaidulina

### 2.1 Observation of available biographical sources

The book «Sofia Gubaidulina, eine biografie» was originally released in 2001 by Michael Kurtz and fortunately, revised and expanded in 2007 as the first English edition, translated by Christoph K. Lohmann. In this biography Kurtz claims that the work, background and origin of the music of Gubaidulina have not been extensively studied.<sup>5</sup> Next to various interviews and a few analyses of individual works, there are two books published: The first was an Italian monograph by Enzo Restagno and Valentina Kholopova, published in 1991 along with a Russian translation five years later. The second was «Rhythm of form», a comprehensive study by musicologist Valeria Tsenova, published in Moscow in 1991 along with a German translation in 2001. My linguistics skills are limited to Norwegian and English, thus making it somewhat difficult for me to use other sources in German or Russian.

The following biographical portrait of Gubaidulina will be based on the knowledge attained by the book of Michael Kurtz, as well as other interviews and scholar publications. In spite of the strong critique against what Schmelz calls an absence of objective perspective on Gubaidulina in the book<sup>6</sup>, he is evidently praising the value of the book as an effective, coherent introduction to the life of Sofia for those who does not speak Russian or German, and he claims it creates a good ground for future study of the composer.<sup>7</sup>

### 2.2 Early years

Sofia Gubaidulina, the daughter of a Tatar father and Russian mother, grew up in Kazan, the largest city of the Republic of Tatarstan. The diversity between these ethnic groups has repeatedly led to conflicts between the leaders, both under the Tsardom of Russia (1547-1721) and under the

---

<sup>5</sup> Michael Kurtz, *Sofia Gubaidulina*, translated by Christoph K. Lohmann, (Indiana University Press, 2007), xvi.

<sup>6</sup> Peter J. Schmelz, «Review of Sofia Gubaidulina», (Notes, Sep. 2008), 84-87.

In a review of the biography by Peter J. Schmelz in 2008, it specifies a certain critique of the book's lacking of critical engagement with many of the topics and, perhaps most important, that it does not provide specific details of the music, mostly parts of descriptions of the pieces; there is only one exception of a musical example, and that is a page from the electroacoustic piece *Vivente - non Vivente* (1970, translated as *living-not living*).

<sup>7</sup> Ibid.

leadership of Soviet.<sup>8</sup> The dramatic history between Tatars and Russians involves both violence, misery and suffering on both sides; the Mongol invasion of Rus' (1223–1240, referred to as «Tatar yoke») and the «Russification» of Ivan the Terrible (1533-1584), being two examples.<sup>9</sup>

Since the downfall of the Soviet Union, attitudes of nationalism grew over Russia and resulted in many activities of destructive ostracism and chauvinism. Gubaidulina, as a «half breed» of Tatar and Russian experienced the excess of nationalism, and situates the importance of humanness in an interview from 1992: «For me, the important thing is not nationality but humanity as a whole».<sup>10</sup>

The father, Asgad Masgudovich Gubaidullin, was a Soviet engineer of geodetics and the grandfather Magsud Gabdulgalevich Gubaidullin, a Muslim Imam, described by Kurtz as intelligent, cosmopolitan, practical and very religious. The mother, Fedosia Fyodorovna Elkhova, was a teacher, and in the summer of 1931 the third daughter, Sofia, was born in Chistopol. The year after the birth was the dispatch of the antireligious «five-year-plan», with the objective of demolishing all religious architecture throughout the Soviet Union and dispose the word «God» from the language, as something saved from the medieval past used for the misery of farmers and workers.<sup>11</sup>

The same year, the State protracted its ideological discipline over artists and writers, demanding the formation of unions and asserted that they expressed compliments to the new Soviet State. Sofia often felt alone; as she was often left with her dad when the other two older sisters were included with their mother on errands. Feeling left with a certain distance from her sisters, she was described as a bit shy, but with a tendency of a passionate and explosive temperament. On any occasion the family went out, she preferred to stay at home to nourish in her fantasy and imagination.

As a five year old she discovered music and the accordion, by listening to a young man that played in the neighboring backyards mostly for the old babushkas and children. Described as a mildly retarded man lacking a job; nevertheless, he played with talent and enthusiasm and made Gubaidulina enchanted with the sounds of his instrument. Soon she started to improvise an unconscious dance, and an old babushka noticed this and talked to her mother to get her to take piano lessons.<sup>12</sup> At these lessons she only learned easy children-pieces within a two-octave range,

---

<sup>8</sup> Kurtz, *Sofia Gubaidulina*, 1.

<sup>9</sup> *Ibid*, 2.

<sup>10</sup> Göran Fant quoted in Kurtz, *Sofia Gubaidulina*, 70.

<sup>11</sup> Kurtz, *Sofia Gubaidulina*, 8.

<sup>12</sup> *Ibid*, 11.

but soon she discovered the unexpected difference of tone, timbre and color. She encountered this by playing in the lowest and highest registers on the keys, but also from the inside of the instrument, - planting pieces of paper, cloth and pencils between the strings. Her curiosity as a child led to the creative exploration of the instrument's rich world of sound, while at the same time, the twenty-six-year-old John Cage was writing his first piece for prepared piano, *Bacchanale*.<sup>13</sup>

The summer before Sofia entered the music school, the family stayed at a village in the hills, and Sofia observed an icon of Christ. Regardless of the powerful campaign to inhibit religion, some people stayed truthful to their fate and symbols. It was here Sofia understood the connection of her secret prayers in their backyard and the icon. After asking her mother what the icon pictured and revealing her religious beliefs, these forbidden thoughts of faith frightened the parents. In an interview with Maria Bogatyryova in 1991, Gubaidulina recalled this movement and said: «So I started hiding my emotional, religious life from the grownups, but it continued to thrive within me. Music naturally blended with religion, and sound, straightaway, became sacred for me.»<sup>14</sup>

Her father frequently said that *silence is golden*, and the trips Sofia had alone with her father on the countryside were filled by complete silences. Sofia later stated that these excursions created a deep and mysterious bond between herself and her father. She was not sure that he felt it, but she said she never experienced anything so profound again later in life.<sup>15</sup> Silence is an important part of Tatar etiquette, where it is seen as a statement of hospitality, when a guest is welcomed to share a meal, to make sure that the conversation develop slowly. Silence is indeed one important quality in the music of Gubaidulina, something that possibly erupted from these influences as a child. Sofia had progressed rapidly in her piano lessons and at the age of ten, she kept her longing to become a composer to herself, praying to God to guide a way out of the disorientation of being small and shy.<sup>16</sup>

In 1946 Sofia graduated from elementary school and entered the Kazan Music Gymnasium in the summer of 1946. She attended this school for three years as a preparation for entering to the conservatory. At the conservatory she attended compositional classes, and in 1949 she began to take piano classes at the Kazan Conservatory. The contemporary program that was played publicly during the post-war was mostly unproblematic works of Shostakovich and Prokofiev, and the opera-theatre mostly played works by Verdi, Tchaikovsky and Rimsky-Korsakov. In the early part of her

---

<sup>13</sup> Ibid, 13.

<sup>14</sup> Maria Bogatyryova, quoted in Kurtz, *Sofia Gubaidulina*, 14.

<sup>15</sup> Kurtz, *Sofia Gubaidulina*, 15.

<sup>16</sup> Ibid, 16.

education at Kazan, Wagner's operas were her favorite, though she only knew them by score and never heard them.<sup>17</sup>

The piano-class, led by Muscovite Lukomsky, gave her the advice «Listen to everybody, but never follow anyone», as if he anticipated her uncompromising nature of art. Furthermore, she heard a composition by the student Edison Denisov for the first time, without knowing that they would later both represent the most prominent names in Russian avant-garde music.

In 1954 she started her graduate studies in composition at the Moscow Conservatory, under Nikolai Peiko and postgraduate with Vissarion Shebalin. Dmitri Shostakovich, the «father» for the entire generation of composers in Russia, said to Sofia after hearing her play her first symphony on the piano; "My wish for you is that you should continue on your own, *incorrect way*".<sup>18</sup>

### 2.3 Later Years

For the search of her own way, Sofia rejected the possibility of a pedagogical profession to become a freelance composer, encouraged by a first prize award in a competition for the piece *Sound of the Forest* (for flute and piano) and publications of the works *Quintet*, *Chaconne* and *Piano Sonata*.<sup>19</sup> The year 1965 became a defining moment for Gubaidulina's work. From 1965-1977, a period that defines the early stages of her mature compositional style, chamber music was of most importance to her writing, with approximately twenty-five works.

Her individual style is reflected in many of these pieces, as she searches for the world of unusual, rarely used timbres and methods of producing sounds. From 1978-1991, Gubaidulina started to explore the expressiveness of the vocal line and the subject of spirituality, as well as rhythmical searches and methods of expressing time through music. A crucial inspiration was the Golden ratio and Fibonacci series.<sup>20</sup> In an interview with Vera Lukomsky in 1998, she stated: "I became preoccupied with completely different concepts – in particular, with issues of the rhythm

---

<sup>17</sup> Ibid, 23.

<sup>18</sup> Ibid, 45.

<sup>19</sup> Alfred Cramer, *Musicians & composers of the 20th century, Gubaidulina-Sofia*, (Salem press, 2009), 547.

<sup>20</sup> A Golden section is a division of the whole into two parts such as the ratio of the smaller to the larger is the same as that of the larger to the whole (the approximate formula of this ratio is 0.618 to 1).

The Fibonacci series is a sequence of numbers, in which each number is the sum of the two preceding numbers (0, 1, 1, 2, 3, 5, 8, 13, 21, 34 ...). The ratio between any two neighbouring numbers is an approximation of the Golden section.

of form...Fibonacci series was crucial in my experiments with musical form in the 1980s...The Golden Section is a fantastic proportion.... I was greatly inspired".<sup>21</sup>

## 2.4 Meeting Friedrich Lips

Friedrich Lips (born November the 18th 1948), started teaching the classical accordion at the Gnesin institute for Music Education in 1971, even before he took his exams in 1974. His efforts has led to foster new literature for the 'bayan-accordion' from significant composers such as Edison Denisov and Alfred Schnittke, many of which have already achieved historical value. More importantly to this subject, he was the man who inspired Gubaidulina to create new pieces for the accordion.<sup>22</sup>

Friedrich Lips and his friendship with the composer Wladislav Zolotariew, who also played the bayan, changed the performer's artistic direction. As a student he was inspired to play transcriptions of what he considered masterworks for the organ, as Friedrich Lips was not satisfied with the level of original music for the instrument. But, he identified himself with Zolotariew's music, and the composer continued to write for Lips. Zolotariew stated that every instrument must have its identity, and he told Lips that he must dream that someone like Gubaidulina write for accordion. Zolotariew wanted to be a part of the Composers Union group in Russia, and Gubaidulina heard Lips perform Zolotariew's third Sonata and recommended him, something which made him part of the organization. This was the beginning of the relationship between Gubaidulina and Lips. The 13th of May 1975, Zolotariew tragically committed suicide.

Lips had asked Gubaidulina what she thought about the instrument and whether she wanted to compose a piece for it, where she replied: "I would gladly write a work for the bayan, but I must familiarize myself with this instrument, that is to say, I do not know it all".<sup>23</sup>

Their collaboration began soon thereafter, as Lips later recalled:

She came to me at the [Gnesin] Institute, in the classroom, and at home. I naturally explained to her all the possibilities of the instrument.... However, I was astonished how pedantically she asked about all the details, how meticulously she probed every detail which seemed of little importance to us bayan players. She was striving, one can say, to penetrate under the hide of this monster, (as she subsequently called the

---

<sup>21</sup> Vera Lukomsky. "The Eucharist in my fantasy: Interview with Sofia Gubaidulina", (*Tempo* 206, Oct. 1998), 34-35.

<sup>22</sup> "Biography". *Music For Accordion*. <http://www.musicforaccordion.com/boutique/inform/lips/lips.htm> (5/4/17).

<sup>23</sup> Gubaidulina quoted in Kurtz, 134.

bayan) and to get to know it from inside.<sup>24</sup>

Gubaidulina completed her first composition for bayan, *De Profundis* in 1978. She took the score and played it for Lips on the piano at the Gnesin Institute. He later recalled:

I was enchanted not only with the music, but also how well she used the reed of the bayan which showed the acoustic potential of the instrument in a fresh new way. At my request she introduced for the first time into Russian musical literature the tonal glissando [for the bayan]. Of course I had to make some editorial corrections, when working on this piece, to ... make the notation more comfortable for bayan players, but this was not work, but a pleasure.<sup>25</sup>

Lips has performed this piece since the early 1980s, "hundreds of times in the USSR and other countries".<sup>26</sup> The second solo piece for bayan by Gubaidulina, *Et Exspecto*, a sonata in five movements was composed in 1985 and also dedicated to Friedrich Lips. At this time, when she met him to discuss the various aspects of the composition, she pointed to the instrument and said: "Do you know why I love this monster so much? Because it breathes".<sup>27</sup>

## 2.5 Symbolism

Vera Lukomsky has provided several interviews with Sofia Gubaidulina and these articles are important due to some statements by Gubaidulina to the importance of religion and spirituality in her life. In a discussion about symbolism in instrumentation, Gubaidulina stated: "I like very much the idea of instrumental symbolism, when the instrument itself, its nature and individuality, hints at or implies a certain meaning. The instrument's quality and the meaning of music join each other... I wanted to find the idea of the cross in the instruments themselves".<sup>28</sup> Therefore, the symbolic appearance, particularly for religious intentions, is a crucial aspect to Gubaidulina's aesthetics.

---

<sup>24</sup> Lips quotes in Kurtz, 134.

<sup>25</sup> Ibid.

<sup>26</sup> Ibid.

<sup>27</sup> Gubaidulina quoted in Kurtz, Ibid.

<sup>28</sup> Gubaidulina quoted in Vera Lukomsky. "Sofia Gubaidulina: My Desire is Always to Rebel, To Swim Against the Stream!" (*Perspectives of New Music* 36:1, Winter 1998), 20.



Religion was suppressed by the Soviet regime and religious beliefs became an expression of rebellion against authority. Still, the depth of Gubaidulina's religious beliefs are manifested to her inner core and the spiritual symbolic intensions are profounder than strictly a desire to rebel against the state. Religion is the main concern of inspiration in Gubaidulina's creative works and she explains her understanding of 'religion':<sup>29</sup>

I understand the word "religion" in its literal sense. That is as "re-ligio" a reestablishment of "legato", of connection. And I am totally convinced there is no more serious task for the artist than to recreate this connection because our whole life is fragmented. Daily life takes place in a kind of staccato. We have no time to create any continuity in our lives. But culture helps us draw a line and so this "legato" is essentially a religious act.<sup>30</sup>

Gubaidulina desires that her music shall recreate the connection between ourselves, our lives, and God. The meaning of culture, she believes, is to unite us with our spiritual side for the hope of an eventual reunion with God.

As far as the connection between the process of composition and religious art is concerned, I feel there is no doubt that these activities are very close to each other in consciousness. You'll remember I said that religion means the recreation of a link with something above us, with God [...] Religion is a link with God. Essentially the artistic work, the artistic act, fulfills this task. It brings together the fragmented impressions of our consciousness into a whole.

In essence, the artistic act is a manifestation of our subconscious on the surface of our life. The artist extracts the plurality of this information, which is inside us, which is hidden from us, from the dark chamber of our subconscious and gives it a unified form, and that is a religious act. It is important that an artistic work deals with the task of extracting the richness of the information in our subconscious. Essentially it is the same kind of human activity.<sup>31</sup>

---

<sup>29</sup> Caroline M. Askew, "Sources of inspiration in the music of Sofia Gubaidulina: Compositional aesthetics and procedures", (Phd., University of Huddersfield 2002), 89-90.

<sup>30</sup> Gubaidulina quoted in Askew, *Sources of inspiration in the music of Sofia Gubaidulina: Compositional aesthetics and procedures*, 90.

<sup>31</sup> Ibid.

The censorship by the state led to a strict control of music through the sponsorship of the Composers' Union. The conditions required composers to write in certain styles and to subjects that were acceptable to the Party. This led many composers towards symbolism as an expression. The composer Alexander Ivashkin describes symbolism as a characteristic feature of Russian music:

For many years we weren't allowed to speak or show what we thought, and consequently, a strange thing happened. When something came into the open, part of it stayed hidden like an iceberg with only a small part above water. So, symbolism became very characteristic of Russian music. Symbolism of the simplest things - an interval, sound, or rhythm became a symbol with which the listener could fantasize. Music became the bridge to a thought or philosophical concept rather than an end in itself. It was never a simple sound construction.<sup>32</sup>







## 2.6 Dichotomy

*Dichotomy* is one example of a central part of the music of Gubaidulina, which is implied and treated as a representation of symbolic meaning. The terminology is defined as a division of two mutually exclusive, opposed or contradictory groups, and used in this relation to connect different expressions of musical objects and patterns. Some essential sound-objects are illustrated with the typology of spectromorphology in the next figure (2.1).

● —	● —
high pitch	low pitch
● —	■ —
pitched sound	complex texture (cluster)
⋮ ≡≡	■ —
chord	complex texture(cluster)
● —	● - - - -
sustained pitch	iterated pitch

---

<sup>32</sup> Alexander Ivashkin quoted in Askew, *Sources of inspiration in the music of Sofia Gubaidulina: Compositional aesthetics and procedures*, 93.

 accumulation	 stagnation
 variable sound	 stable sound
 pitched sound	 unvoiced complex sound

**Figure 2.1 - Examples of dichotomy**

In the publication *Musical contents and symbolic interpretation in Sofia Gubaidulina's "Two Paths: A dedication to Mary and Martha"*, Young-Mi Lee states that the idea of dichotomy is based on the composer's theological beliefs where heaven and earth, the divine and the human coexist with contradictory natures.<sup>33</sup>

## 2.7 Transfiguration

Another representation of symbolic meaning in Gubaidulina's music, is the transfiguration. The transformation of sounds may serve as a representation of the transition to another reality, such as the transfiguration as a symbolization of the two spheres - earth and heaven. Transfiguration in the music by Gubaidulina could be perceived by the transformation of sounds, such as timbral changes that represents symbolic roles.<sup>34</sup> These symbolic representations could represent a sense of 'crossing over to a different dimension'.

The transfiguration of sonic and timbral elements coexist in the spheres of dichotomy, the possibilities of finding new ways of articulating transformations and contradictory relations in the aural analysis are many, and I wish to present some original methods of discovering these aspects in the analysis of the selected works.

<sup>33</sup> *Musical contents and symbolic interpretation in Sofia Gubaidulina's "Two Paths: A dedication to Mary and Martha"*, Young-Mi Lee, 55.

<sup>34</sup> *Ibid*, 60.

# 3 Method Part I

## 3.1 Clarifications

The aural analyses conducted in this thesis represent a relevant documentation of this research, as a large part of this process has been dedicated to the work. The *Acousmographie*, which is the program that allows an analyzer to design a digital aural analysis, does not illustrate signs automatically. Each sign is conducted with a manual operation and is a result of an aural evaluation. This is a thesis in applied music theory, which means a large part of the work has been dedicated to learn and use of the analytic method.

## 3.2 Aural Sonology

Aural sonology is the method of analyzing a musical recording as heard, as the music evolves into a phenomenon of sonic and structural elements. The sound objects is interpreted through these listening intensions and the process occurs from a phenomenological perspective, - through the listener's structural consciousness.<sup>35</sup> The intention to grasp the sound itself as a sound-object is established through the idea of *reductive listening*. Reductive listening is an attitude of listening to the sound as a sound object, by removing its real or supposed source and the meaning it may convey.<sup>36</sup>

Pierre Schaeffer, whose groundbreaking work represents the outset of what would become the aural sonology project, introduces the term reductive listening. The French composer and music theorist is known to be a pioneer of *Musique Concrète*, the movement and style of using new techniques of recording raw sounds such as trains, dog-barking and a storm to create a new line of music. This innovative style creates a discourse of music-theory as well as philosophy in relation to questions such as the definition of what sound objects, textures and timbres in music may be. Besides the reductive consideration of isolated sound-objects, there is a perception of an entirety which is organized through «gestalts», a word often used as a psychological study of form.<sup>37</sup> The quality of a whole cannot be entirely reduced to its pieces and cannot be perceived independently of them. The parts may be observed and described, but the whole remains an

---

<sup>35</sup> The study of structural consciousness concerns the experience; first-person's point of view. The fundamental structure of an experience is its intentionality, which is being directed toward an object.

David Woodruff Smith, "Phenomenology". Edward N. Zalta (ed.), (*The Stanford Encyclopedia of Philosophy*, 2016) <https://plato.stanford.edu/archives/win2016/entries/phenomenology/> (28.02.17).

<sup>36</sup> Michel Chion quoted in Thoresen, *Emergent Musical Forms*, 10.

<sup>37</sup> Ibid, 10-11.

emergent phenomenon.<sup>38</sup>

The level of reductive listening, referred to as level one in Emergent Musical Forms, is related to the process of echoic memory of a musical experience. This level could be left in order to grasp other levels of gestalts, such as the consideration of sound-patterns (level two) and form-building processes (level three), and what semiotic implications these levels may convey. The perception of patterns in level two connects to the applied intention of *taxonomic listening*; its focus is how music is perceived and organized in patterns. While the reductive listening is related to the echoic memory, the perception of patterns relates to the short memory processes of a musical experience. The taxonomic listening intention also benefits the study of how sound-patterns are integrated to larger forms, or "patterns of patterns," and relates to the long-term memory. A taxonomic listening intention is therefore also applied in the third level of articulation; the analyses of form-building gestalts.

<i>Articulations</i>	<i>Considerations</i>	<i>Listening intensions</i>	<i>Process of experience</i>
Level one	Analysis of sound-objects	Reductive listening	Echoic memory
Level two	Analysis of sound-patterns	Taxonomic listening	Short-term memory
Level three	Analysis of form-building patterns	Taxonomic listening	Long-term memory

**Figure 3.1 - Articulation levels**

In addition to phenomenology, aural sonology grasps different theoretical methods such as hermeneutics and semiotics:

Thus what we propose is a synthesis: Phenomenology informs our approach to listening intentions and object constitution while at the same time it helps us to avoid a reductionist perspective; elements of structuralism and semiotics serve to reveal the logical relationships between musical elements. Through process of a hermeneutical exegesis involving repeated listening and tentative analyses, the analyst may eventually arrive at a condensed comprehension.<sup>39</sup>

---

<sup>38</sup> Thoresen, *Emergent musical forms*, 197.

<sup>39</sup> *Ibid*, xxviii.

Musical patterns and other elements may be perceived as signs, and each sign has a functional association of meaning for the perceiver. The sounds are communicating in relation to each other and the perceiver may organize a logical function of interpretational meaning.

One of the strengths and goals of using the theory of aural sonology, is gaining an aural consciousness either as a performer, composer, theorist or a listener:

The ability to discern different listening intentions is actually one of the gains that the practice of this method of analysis will yield: Practitioners will develop an aural consciousness that has been made at once more precise and more flexible as the mind expands its powers to envisage musical and compositional possibilities.<sup>40</sup>

My main interest for this project is to explore the interpretation of contemporary repertoire, such as the pieces for solo accordion by Gubaidulina. Still, other musicians may benefit of this theoretic approach in order to study interpretations of recordings.

Musicians will increase their capacity to address certain problems of musical interpretation, such as phrasing, formal articulation, prioritization of parts within an ensemble, and eventually to find specific solutions to his questions.<sup>41</sup>

---

<sup>40</sup> Ibid, xxiii.

<sup>41</sup> Ibid.











### 3.3 Terminology

These sections may provide information to the reader in order to comprehend the terminology that occurs in the aural analysis of *De Profundis*.

#### 3.3.1 Spectromorphology - level one

The articulation of level one is the discovery, study and categorization of sound-objects through reductive listening.<sup>42</sup> Furthermore, the attitude of reductive listening consists of listening to the sound-object by eliminating its source and the meaning it may convey. The systematic study created by Thoresen, developed from the central ideas of Schaeffer's model of listening to the sound-object, is termed *spectromorphology*.<sup>43</sup> The criterion of these categories is based on the energy articulation of the sound and the sound spectrum, which are the aspects of the sound in which the perception of pitch and pitch content is founded.















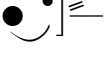

The next figure will illustrate and explain some of the signs and their purpose regarding my analyses. For further study of the typology of spectromorphology, the reader is recommended to read chapter four in *Emergent Musical Forms* or simply explore the website.<sup>44</sup> Figure 3.1 depicts a relevant selection of current signs along with a situated summary of original definitions provided by Lasse Thoresen.

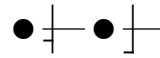
	Pitched sound (sustained)	Sounds that have a clearly perceivable pitch or fundamental (continuous energy)		Cell	An accumulation with a total duration in the range of gesture-time
	Impulse	Short burst of energy		Accumulation	Unpredictably diversified iterations
	Complex or unpitched sound	No perceivable fundamental		Sign of change	Gradual change or transformation
	Unvoiced complex sound	No perception of fundamental, complex spectrum; "unvoiced" sonority		Dyad	A set of two pitches
	Iterated pitch	Discontinuous energy		Chord	A set of three or more pitches

<sup>42</sup> Thoresen, Lasse, *Emergent Musical Forms*, 259.

<sup>43</sup> The term spectromorphology was defined by Denis Smalley who elaborated on Schaeffer's model.

<sup>44</sup> [www.auralsonology.com](http://www.auralsonology.com)

	Variable pitched sound	Sound-objects with a gradual internal development in their sound spectrum (glissandi or sounds with gliding formants)		Variable impulse	Short thrust of energy with gradual internal development in their sound spectrum (glissandi or sounds with gliding formants)
	Pitched iterated sound in flutter-time (regular pulse)	Flutter-time represents a BPM faster than 500		Composite sound	Pair of sounds, such as a grace note added to (or inserted into) a main note, or a trill or mordent
	Sharp ending	Sounds with an ending phase containing elements intrinsic to the main body of sound itself		Composite sound in ripple-time, regular pulse	Ripple-time represents a BPM between 200-500
	Abrupt ending	Sounds with an accentuated ending phase, containing elements alien to the main body of the sound (e.g., a vibrating string dampened with a metal rod)		Variable complex sound-object	Sound-objects with a gradual internal development in their sound spectrum (glissandi or sounds with gliding formants)
	Bright/brightest spectral brightness	The vertical line put on the prolongation line indicates the entire spectrum from high to low		Dark/darkest spectral brightness	The vertical line on the prolongation line indicates the entire spectrum from high to low
	Swelled onset	A short crescendo/decrescendo		Impulse	Short thrust of energy
	Slow, large dynamic gait	The gait of a sound-object is fluctuation of a sustained sound-object and in this example represents the dynamic dimension		Decreasing rit. in regular pulse	Regular pulse divides time into equally long segments
	Middle, moderate dynamic gait	<i>(Gait continues)</i> The gait is analysed with regard to its degree of deviation and its pulse velocity		Decreasing rit. in oblique pulse	Oblique pulse forms an intermediary category between the irregular pulse and regular pulse
	Fast, small dynamic gait	<i>(Gait continues)</i> These three examples of dynamic gait may be combined in aspects of velocity and deviation		Decreasing rit. in irregular pulse	Irregular pulse has no common unit of «measurement» that can be aurally perceived



● ≈---	Irregular ripple time	(See definitions on «decreasing rit. in irregular pulse)	⋈	Increasing rit. in regular pulse	(See definitions above)
● ≈---	Oblique ripple time	(See definitions on «declining rit. in oblique pulse)	≈	Increasing rit. in oblique pulse	(See definitions above)
● ----	Gestural-time	Gestural-time represents a BPM between 25-200	≈	Increasing rit. in irregular pulse	(See definitions above)

**Figure 3.2 - Typology of spectromorphology used in the analyses**

Examples of complex sounds (■—) that may emerge from the accordion could be a complex texture such as a cluster of pitches or an unpitched, percussive slam on the instrument itself. A variable complex texture (■/), may represent cluster glissandi in the music. Unvoiced complex sounds (□—), may represent sound-objects such as the air-button on the instrument or other sounds that create a «hush-sound». An iterated pitch (●----) may represent a sound-object caused by a bellow shake made by the instrument or repetitive fingering articulations.<sup>45</sup>

### 3.2.2 Endosemantic analysis of harmonicity (harmonic colors) - level two

Level two represents the level of compound sound-patterns. Thoresen does not emphasize specific concepts of applied methods for the analyst, unlike to level one and level three. More importantly, he does propose ideas of how analyses of sound-patterns may be created with aural sonology. The reason is elucidated: level two has already received a huge amount of attention in interval-based music, such as tonal music theory. The analyses of compound sound-patterns may in most cases be a helpful understanding of specific styles, where different musical dimensions may be discussed. These dimensions are seemingly immense and are therefore not restricted to specific concepts of applied methods. One musical dimension that emerges to the listener of Gubaidulina, may be the transforming, endosemantic patterns of harmonicity. A description of *endosemantic* entities is the interpretation of elements within a musical work, such as appointing functions to the relationships between different elements.<sup>46</sup> These categories are situated on level two (sound



<sup>45</sup> Bellow shake is a repeated change of direction of the bellow, creating an iterated articulation of energy.

<sup>46</sup> Thoresen, *Emergent Musical Forms*, 346-347.

patterns) and these contextual meanings may be organized as isotopes.<sup>47</sup>

The origin of the word *endo* comes from the Greek word *endon* (from within) and endosemantics connects with meaning from within.<sup>48</sup> *Exosemantic* (origin from Greek *exō-* outside) references however, concern meaning outside the musical discourse and do not participate in this category. Yet, the endosemantic categories of intra-musical relationships may be interpreted exosemantically, thus being regarded as the signifiers in an exosemantic interpretation. I wish to apply this process in order to present examples of interpretative meaning through symbolism as heard, in light of the performer's interpretation of the selected works.

One of the most characteristic and enigmatic elements of *De Profundis*, is the process of harmonicity. The harmonicity expands from the perception of diatonic chorales to chromatic counterpoint, and further to developments of clusters. Three apparent isotopes emerge of consisting harmonic perception: complex harmonies, dissonant harmonies and consonant harmonies. These elements are represented in the aural analysis by colors, inside the model of dynamic form-fields, which will be introduced in the chapter 3.2.4.

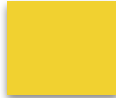
		
Complexity	Dissonance	Consonance

**Figure 3.3 Harmonic colors**

With this scale (fig. 3.3) I have created a colored spectral profile of the harmonicities. Black represent complex, green represents dissonance and yellow represents consonance. Using colors creates the opportunity to further express the degree between these elements.

---

<sup>47</sup> In semiotics, we detect an isotopy when there is a repetition of a basic meaning trait (seme). This establish a level of familiarity. An example may be «I drink some water», where the words drink and water share a seme (a reference to liquids).

<sup>48</sup> *Oxford Dictionary of English*, (Oxford University Press), <https://en.oxforddictionaries.com/definition/us/endo-> (15.03.17).

BLACK	DARK GREEN	BRIGHT GREEN	YELLOW
COMPLEX	LESSER COMPLEX/ MORE DISSONANCE	LESS DISSONANCE/ MORE CONSONANCE	CONSONANCE

**Figure 3.4 Harmonic categories**

The coagulation of colors represents certain transitions between the isotopes, making it easier to articulate a harmonic evolution. By using examples of fifteen suitable harmonies from *De Profundis*, the listener may establish an illustrative scale of harmonic development that provides further explorations. The aural observation is accentuated as a key tool of defining aspects. This scale is therefore not obligated by the use of certain interval-calculations or other theoretical aspects of analysis that does not concern the dimension of phenomenology.

The consideration of these harmonies is based on three measurements: size, register and mass, which are used as calculations between two borders of references (complexity and consonance).

<i>Dimensions</i>	<i>Complexity</i>	<i>Consonance</i>
Size	Thick	Thin
Low register vs. high register	Opaque	Clear
Mass	Dense	Spread

**Figure 3.5 Considerations of harmonies**

Through these dimensions the perceiver may establish a process of an emerging harmonic metamorphosis, between the selections of fifteen harmonies, ranging from a considerable cluster to a luminous major-chord. The structure of the metamorphosis is not continuous in the piece itself, but remains as an enigmatic development of character.



Figure 3.6 Complexity scale - Harmonic metamorphosis<sup>49</sup>

The purpose of combining concepts from biology, namely the transformation of the evolving young insect with the situated harmonies, is purely metaphoric. Some of the transformation-stages are situated underneath the gradient of colors. The metamorphosis of an insect, such as the butterfly, consists of four sequences; the embryo, the larva, the pupa and the imago.<sup>50</sup> The last two stages are applied as a metaphor on complex harmonicity to consonant; from the cocoon (pupa) to the butterfly (imago).

The next model represents explanations of the terms situated underneath the colors and expresses the different states that are found in the different harmonies of the complexity-scale.

<sup>49</sup> Harmony orders in De Profundis: **1.** page ten, fifth staff, **2.** page eleven, third staff, **3.** page two-fifth staff, **4.** page three-first staff, **5.** page two-first staff, **6.** page one-first staff, **7.** page one-fifth staff, **8.** page five-first staff, **9.** page five-first staff, **10.** page twelve-first staff, **11.** page twelve-last staff, **12.** page three-second staff, **13.** page three-second staff, **14.** page thirteen-second staff, **15.** page ten-second last staff.

<sup>50</sup> "Butterfly Life Cycle", *The Academy of Natural Sciences of Drexel University*: <http://www.ansp.org/explore/online-exhibits/butterflies/lifecycle/>. (14/03/17).

Terminology	Process	Metaphor
Pupa(cocoon)	The protective holster of the insect larva	Great complex cluster is perceived
Contraction	Shrinking	Cluster dissolves
Expanding	New process emerge	Dissonance is achieved and it gradually grows more consonance
Molting	Sheds «old» skin, newer skin underneath is exposed	Major-chord is perceived, simultaneous with large cluster
Emergence	The process of reaching its outgrown-state	Prominent consonance simultaneous with dissonance is perceived
Imago	The insect attains maturity	Clear consonant is achieved

**Figure 3.7 - States of harmonic transformation**

### 3.2.3 Time fields - level three

The typology of time-fields represents the successive units in a musical discourse; they are subdivisions of larger musical entities, organized into smaller segments that are perceptible to the listener.<sup>51</sup>

Traditional examples of these smaller segments are the idea of a motif (a short musical idea, figure or fragment), musical phrase or sentence. The definitions of time-field entities do not solely rely on these traditional terms, as the method emphasizes a span over stylistic borders such as contemporary and sound-based music; these may not serve the same structural function as traditional classical music. The term *field* is accentuated in Emergent Musical Forms and represents «an open space».

The approach of defining such a musical field is through the orientation towards primary perceptive forces at work in the formation of aural gestalts.<sup>52</sup> Therefore, an analysis of time-fields is in itself an interpretation, as the listener will find how the music articulates itself into phrases.

---

<sup>51</sup> Thoresen, *Emergent musical forms*, 351.

<sup>52</sup> Ibid, 352.

The music is approached at its face value, beginning roughly with the same view as a listener in a concert. As the listener proceeds to repeat the listening, it provides clarity to first impressions and further engages the analyst in an analytic process related to a hermeneutic process that perhaps proves more critical reflections compared to initial impressions.<sup>53</sup>

Lasse Thoresen refers to Bob Snyder, who distinguishes three principles by which music can be divided into events, in order to help grasping the extended music.<sup>54</sup>

*Proximity*

Elements that occur in rapid succession integrate; longer durations in a context of short events tend to mark the boundary of a group.

*Similarity*

Similar sound-objects tend to be grouped together. Similarity may exist between various features of the sound (such as loudness, timbre, pitch, duration).

*Continuity*

Sound-objects included in the same directional tendency will easily be grouped together. This gestalt factor may underlie the importance of linearity in order to establish coherence.

The shorter time-fields are assembled into longer units that form a hierarchy of shorter and longer time-fields. This hierarchy of units is perceived simultaneously in the temporal continuum of the musical organization. Thoresen compares this characterization with the organization of verbal languages, where the sentence is subdivided into shorter, word groups, words, phonemes, while the sentence itself is a part of longer units of speech such as sections and chapters. In this musical hierarchy there are three levels of musical organization and perception; sound-objects, sound-patterns and form building gestalts.<sup>55</sup>

The shortest fields may then be called object-fields (Field<sub>0</sub>). Here, sound-events are grouped into elementary units often functioning as motive. On the second field level (Field<sub>1</sub>), one may speak of phrase-fields: usually a musical phrase or a partly completed portion of a larger musical sentence. One field level deeper (Field<sub>2</sub>), one can identify the sentence-field; a unit consisting of a number of phrase-fields, often terminated by a full cadence. Finally,

---

<sup>53</sup> Ibid, 353.

<sup>54</sup> Snyder quoted in Thoresen, *Emergent musical forms*, 353-354.

<sup>55</sup> Thoresen, *Emergent musical forms*, 355.

there is the level of the form-field (Field<sub>3</sub>) in which a constellation of several sentence-fields forms a larger section of a composition as a whole.<sup>56</sup>

Time-field levels	Designation	Graphic Notation	
		In full	Shorthand
Field depth 0	Object-field/Field <sub>0</sub>	┌-----┐	┌. .┐
Field depth 1	Phrase-field/Field <sub>1</sub>	┌────────┐	┌── ─┐
Field depth 2	Sentence-field/Field <sub>2</sub>	┌════════┐	┌═ ═┐
Field depth 3	Form-field/Field <sub>3</sub>	┌═════════┐	┌══ ══┐
Field depth 4	Field <sub>4</sub>	┌══════════┐	┌═══ ═══┐

**Figure 3.8 - Notation of time-field depth<sup>57</sup>**

It is intriguing to interpret the designations of fields in the music of Gubaidulina, as the music clearly expresses functional levels. Musical phrases and sentences in her music may be compared to style-references of Western classical music, such as a style resembling baroque music. Still it might throw itself in a further direction of experimental «avant-garde», where the sound itself defines the field and functional designations are either abandoned or less emphasized.

Moreover, the next models illustrate how time-field combinations may be linked, and the signs are organized into two subcategories: field positioning and field demarcation.

Designation	Notation	Definition
Separate positioning	┌──┐ √ ┌──┐	Two time-fields are separated with a noticeable silence.
Bridged positioning	┌──┐ / ┌──┐	Two time-fields are joined by the help of a transitional passage or by an uninterrupted background.
Joint positioning	┌──┐ ┌──┐	The next time-field begins just after the first one is ended.
Close positioning	┌──┐ ┌──┐	The second time-field takes over in very tight succession.
Hinged positioning	┌──┐ ┌──┐	The end object of the previous time-field coincides with the beginning of the next.
Overlapping positioning	┌──┐ ┌──┐	The second time-field begins before the first is ended.
Superimposed positioning	┌──┐ ┌──┐	Time-fields in layers are superimposed.

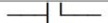

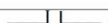
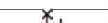

**Figure 3.9 Time-field positioning<sup>58</sup>**

<sup>56</sup> Ibid, 355-356.

<sup>57</sup> Ibid, 356.

<sup>58</sup> Ibid, 358.

The sign indicating 'noticeable silence' is used somewhat carefully in the analyses, as silence may operate on a large scale in the music of Gubaidulina. Therefore, a noticeable silence will be applied in order to articulate significant silences in the music, oppose to shorter disjunctions between musical elements.

Designation	Notation	Definition
Vague demarcation		It is not clear exactly where one field starts and another ends.
Open demarcation		A more or less 'rounded' ending suggesting a continuation.
Conclusive demarcation		The ending communicates a definite ending of the field, e.g. with a complete, authentic cadence.
Cut demarcation		A sudden time-field ending or an unexpected abbreviation.
Disjointed demarcation		A very abrupt, fragmented time-field ending.
Deferred demarcation		A time-field is unexpectedly prolonged.

**Figure 3.10 Time-field demarcation<sup>59</sup>**

### 3.2.4 Dynamic form - level three

Dynamic forms are established through the large-scale *directional forces* in the perceived music and reveal form-building functions. Directional forces are found in *forces of energy* and *functions*, such as *harmonic* and *metrical functions*. This means that we perceive energy through loudness of the sound-object, dynamics and tempo between sound-patterns and other musical dimensions such as tessitura, tonal modulations, articulation and density of mass. The articulation of tendencies and directions may be the result of shaped energy, meaning it is gradually getting louder, faster, denser, higher et cetera. The stated aspects concern forces of energy, while directionality can also be expressed through musical functions, such as metrical functions (upbeat, downbeat, etc.) and harmonic functions (tonic, dominant, et cetera). These aspects define a small-scale directionality and operate on level two.<sup>60</sup>









<sup>59</sup> Ibid, 359.

<sup>60</sup> Ibid, 419.



The performer has a particular degree of influence upon these form-structures, since dynamic forms are sensitive to changes in tempo and dynamics. Therefore, performances with different interpretations will, to a greater extent, include different dynamic forms, especially regarding the forces of energy, not the different harmonic functions.<sup>61</sup>

There are three form-building functions that relate to the directionality of dynamic forms: *forward-oriented*, *presence-oriented* and *backward-oriented functions*.

Form-building Functions	Emphasis of Form-building functions		
	Average (primary)	Faint (secondary)	Emphasised
<i>Presence-oriented</i> (static tendency)			
<i>Forward-oriented</i> (increasing tendency)			
<i>Backward-oriented</i> (declining tendency)			

**Figure 3.11 Form-building functions<sup>62</sup>**

The *forward-oriented function* is characterised as being *directed towards* a future point in time and/or by an increasing tendency.

The *backward-oriented function* is exactly the inverse: it is characterised by being *directed away* from a past point in time, and/or by decreasing tendency

The *presence-oriented function* is characterised by having a stable(or no) tendency, and, consequently, by being directed toward neither future nor past.

These functions may be represented with different emphasis or weight. Less emphasised functions may be called secondary when they are simultaneous with more predominant(primary) ones.<sup>63</sup>

<sup>61</sup> Ibid, 422.

<sup>62</sup> Ibid, 423.

<sup>63</sup> Ibid. 422.

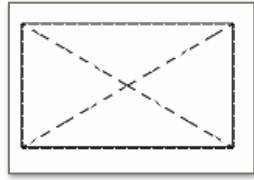

**Figure 3.12 - The neutral form-building function<sup>64</sup>**

Since tendencies are established through several musical dimensions, a form-building function may be ambiguous, and in extreme cases where it is impossible to determine the characteristics of the functions stated in the figure (3.11). This kind of vagueness could be described with a neutral form-sign (fig. 3.12).

An additional dynamic function may be applied to express larger tendencies, which occur simultaneously with the present function. The larger tendencies will be put underneath the shorter tendencies, like this:

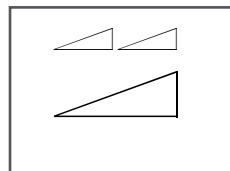

**Figure 3.13 - Extended dynamic tendencies**

The higher dynamic model (the dynamic model on top of the other - fig. 3.13) represents the shorter tendencies, such as a musical part with a concluding crescendo followed by a second musical part with higher intensity than the previous, creating a stronger development of the intensity-profile. An occurrence such as this may be interpreted with a supplementary lower dynamic model (the dynamic model under the other), illustrating the longer tendencies between these dynamic parts. Furthermore, Thoresen points to an important consideration of directionality that is of *goal attainment*; this means that a moving gesture may or may not attain its goal.<sup>65</sup>

*Goal attainment*: a forward-oriented function attains its expected goal.

*Blunted goal attainment*: a forward-oriented function attains its goal but different dimensions arrive at different points in time.



*Suspended goal attainment*: the expected goal of a forward-oriented function is first suspended, but arrives later.

---

<sup>64</sup> Ibid, 423.

<sup>65</sup> Ibid.

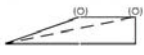
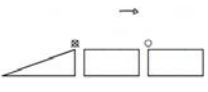
*Goal evasion*: in full goal evasion, the goal is not reached. In partial goal evasion, it is not reached fully or not in the way expected.<sup>66</sup>

Designation	Notation
<i>Goal attainment</i>	
<i>Blunted goal attainment</i>	
<i>Goal suspension</i>	
<i>Full goal evasion (goal cancellation)</i>	
<i>Partial goal evasion</i>	

**Figure 3.14 Goal attainment<sup>67</sup>**

Accents may serve as a function of dynamic forms, as a purpose of musical punctuation.<sup>68</sup>

Thoresen defines accents as intensive or weighted points in time, created to ensnare the attention of the listener briefly. Its criteria must be of prominence from its musical environment, often by having more energy, such as being louder, sharper, longer, etc.

The author defines the following relevant accent functions, illustrated in the next page.

<sup>66</sup> Ibid, 423-424.

<sup>67</sup> Ibid, 424.

<sup>68</sup> Ibid.

Designation	Sign
General sign for accent = weighted point	▼
<i>Goal point</i> . Accent marking goal	▼
<i>Separation point</i> . Accent marking separation of time fields	▼
<i>Release point</i> . Accent marking beginning, or release of motion	▼
<i>Termination point</i> . Accent marking termination	▼
<i>Affirmation point</i> . Accent marking affirmation	▼
<i>Warning point</i> . Accent alerting the listener to imminent event	▼

**Figure 3.15 Accent functions<sup>69</sup>**

An accent can mark out a *goal* for musical movement, thus at the end of a forward-oriented form-building function.

An accent can mark the *border* between successive time-fields, setting them apart from each other.

An accent can mark the *beginning* of a time-field, for example by the launching of a directed motion.

An accent can mark the *ending* of a time-field or a form-building function.

An accent can affirm, repeat or reinforce another accent or previously stated musical elements (thus referring back)

An accent can serve as an alert or warning directed towards a future event.<sup>70</sup>

---

<sup>69</sup> Ibid, 425.

<sup>70</sup> Ibid.

## 4 De Profundis

Through aural sonology, I intend to analyze the recorded performance by Geir Draugsvoll.<sup>71</sup> I wish to provide an extensive, endosemantic analysis of the piece as whole, to further use these endosemantic indications as a material for an exosemantic interpretation.

### 4.1 Geir Draugsvoll

Geir Draugsvoll is considered one of the most important accordion pioneers. He has collaborated with many composers and premiered a large number of works, including *Fachwerk* (2009) by Sofia Gubaidulina, which is dedicated to him. Geir Draugsvoll is Norwegian, but lives and teaches in Copenhagen, Denmark, where he is a Professor at the Royal Danish Academy of Music.<sup>72</sup>

### 4.2 Aural analysis of *De Profundis*

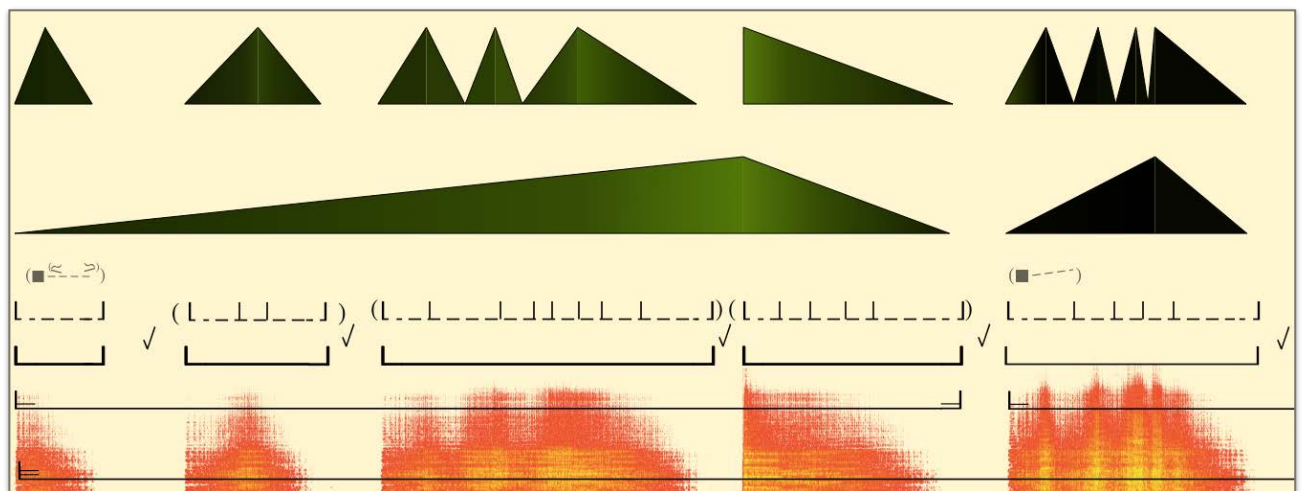

Figure 4.1 - Draugsvoll 0' 01''-1' 17'', 1st video, <http://bit.ly/2prw7y4><sup>73</sup>

The aural analysis (fig. 4.1) depicts an iterated complex sound-object, representing the cluster in the accordion's lower register. The color on the inside of the first dynamic tendency is dark and represent a complex harmonicity. This tendency depicts a hint of green, which indicates its

<sup>71</sup> Sofia Gubaidulina, "De Profundis", Geir Draugsvoll, *Silenzio / De profundis / Et exspecto / In Erwartung* (BIS Records, 1995).

<sup>72</sup> CV, *Pro arte international mangement*, <http://www.proarte.no/dra/draugsvoll.htm>. (10.05.17).

<sup>73</sup> *De Profundis*, Karthause-Schmülling Musikverlag (Deutschland), score, page 1.

short clustered range. The first texture appears and increases its dynamical and rhythmical intensity, shown as increasing tendency, and then dissolves, shown as a declining tendency.

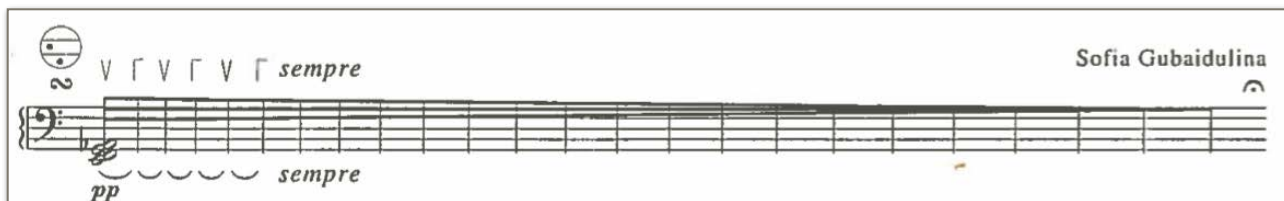

**Figure 4.2 - Score excerpt<sup>74</sup>**

In contrast to the aural analysis, the score itself suggests a presentation that only describes the same texture as a declining tendency, in terms of rhythmic values (fig. 4.2). The score and the analysis differ as the performer includes an accelerando and crescendo to the beginning of the texture.

Between the gestures there is noticeable silence, illustrated with a positioning between the phrase-fields (fig.4.1). For each occurring texture, its loudness increases. The lower dynamic figure in the analysis depicts an increase of energy throughout the motions of the higher dynamic figure. In this context, an emerging intensity is somewhat perceived between these parts through the long-term memory.

The texture establishes a certain character in motion, which consists of two strata; the minor second in the higher part of the chord, which moves in chromatic motion, and the minor second in the lower register that stays unchanged. The motion of the higher strata is irregular, that carefully ascends throughout the sentence-field. The expansion and contraction of range is illustrated as object-fields in parenthesis, indicating its secondary function oppose to the phrase-field focus. The harmonic color within the dynamic tendency (fig. 4.1 - lower tendency), further illustrates the harmonic expansion in register by the higher strata and the change of interval timbre of the texture. The analysis depicts a transformation from complex harmony that slightly evolves towards less complexity, as shown in the analysis as the transition from dark to dark green (fig. 4.1). Therefore, the large increasing tendency is determined, -not only by the increasing loudness and rhythmical intensity of each recurring parts, but also the ascending pitch and expanding harmonicity. The fourth phrase-field (fig. 4.1) establishes the peak of profile energy within the sentence-field as it further dissolves to its original complex texture.

A new sentence-field indicates a new part, where the iterated energy articulation of the

<sup>74</sup> Ibid, page 1, first staff line.

texture is changed from stable energy to variable energy (fig. 4.1). The cluster appears thicker and therefore more complex (indicated with black). The beginning of this texture aurally resembles the opening texture of the piece, as it is slightly less extent of range as a cluster (indicated by a dark green beginning of the higher dynamic model) and the performer establishes a connection to the previous stable iterated texture. The texture appears unified in directions oppose to the previous sentence-field where only one strata was in chromatic motion. The motions of the glissandi resemble the preceding sentence-field; a similar structure of directional tendency, such as rhythmic- and dynamic intensity, and timbral gestures in the range of register (indicated by movements such as *high- low- higher*). The object-fields are perceived as the increase and decrease of rhythmical intensity as one notion of movement.

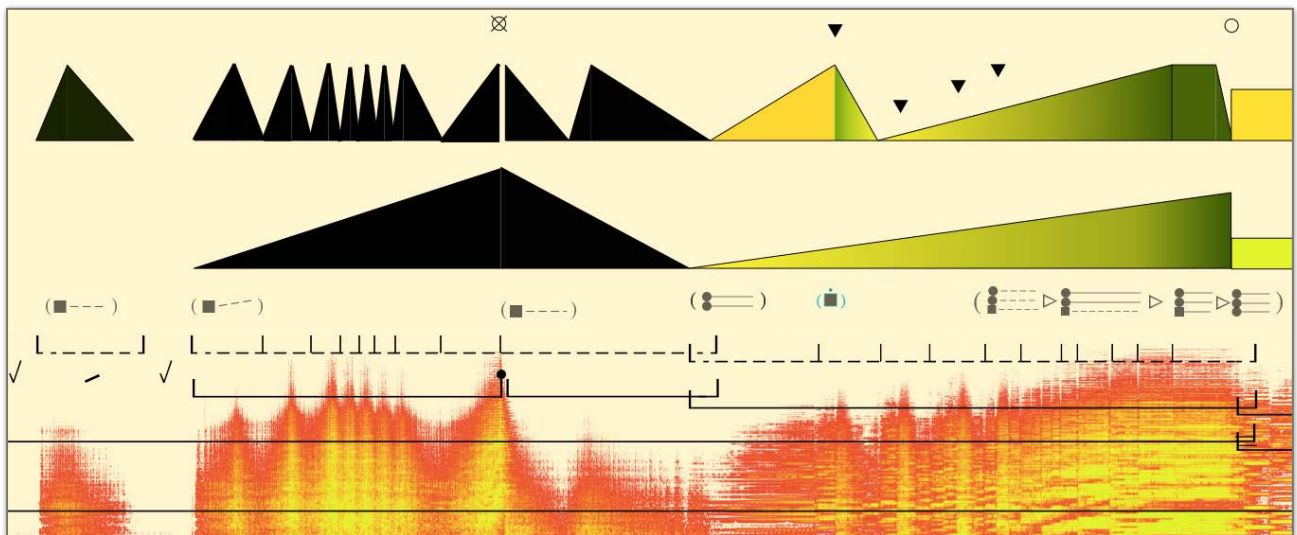

**Figure 4.3 - Draugsvoll 1' 18''-2' 31'', 1st video<sup>75</sup>**

The next object-field resembles the same motion heard as the opening texture of the piece and is marked with a bridged positioning (fig. 4.3). The contrast of the stable-iterated texture is seen in the aural analysis between the phrase-fields of the iterated-glissandi (fig. 4.1+ fig. 4.3).

The following cluster-glissandos are more emphasized and articulated than in the previous development, and for each object-field (defined as one motion of increasing and declining dynamic tendency), the sound-object expand the use of pitch-register. Much like the same way as the opening development of the piece, the objects are gradually exploring a higher range. The peak of the lower dynamic model (fig. 4.3) illustrates the culmination of the phrase-field (marked with the goal cancellation-sign) as it reaches its highest level of pitch and dynamics, but abruptly returns to a lower cluster recognized as the stable iterated texture. The cut demarcation-sign represents the

<sup>75</sup> Ibid, page 2 - page 3, second staff line.

sudden ending of the phrase-field.

A new part begins before the first is ended, as illustrated through hinged positioning between the object- and phrase-field, which results in an expansion of the perceptive sentence-field. A new texture is introduced; a sustained major dyad, the dichotomy of the previous texture.

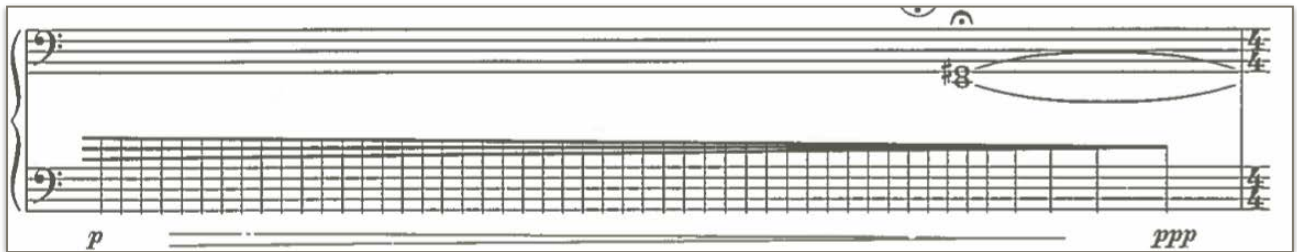

**Figure 4.4 - Score excerpt<sup>76</sup>**

The excerpt (fig. 4.4) depicts a paradox regarding the score and the instrument. The solution is unidiomatic; the score indicates that the performer should continue the bellow shake and at the same time start a sustained sound, something that demands an even handling of the bellow. To recapture the score literally, the accordionist can exchange the bellow shake with rhythmical fingering to be able to use an even bellow, but this will create a different articulated quality of the iterated texture. Instead, the performer makes an artistic recapture of the score, by placing the sustained texture with the last note of the iterated texture.

The sustained dyad indicates consonance and is illustrated with the color yellow (fig. 4.2). The phrase-field represents a chordal motion with increasing segments; from longer to shorter object-groups, higher use of register and a stronger dissonant development.

The object-fields are defined through motions of complex impulses, increasing iterated energy and merging sustained energy. The harmonic development from yellow to dark green is articulated through the aspects of density and thickness of the textures, and is perceived as a gradual transformation from consonance to dissonance. The last object-field represents the brightest, loudest and most dissonant texture. This leads to the designation of the first part of the piece, marked with a goal attainment.

<sup>76</sup> Ibid, page 2, fourth staff line.



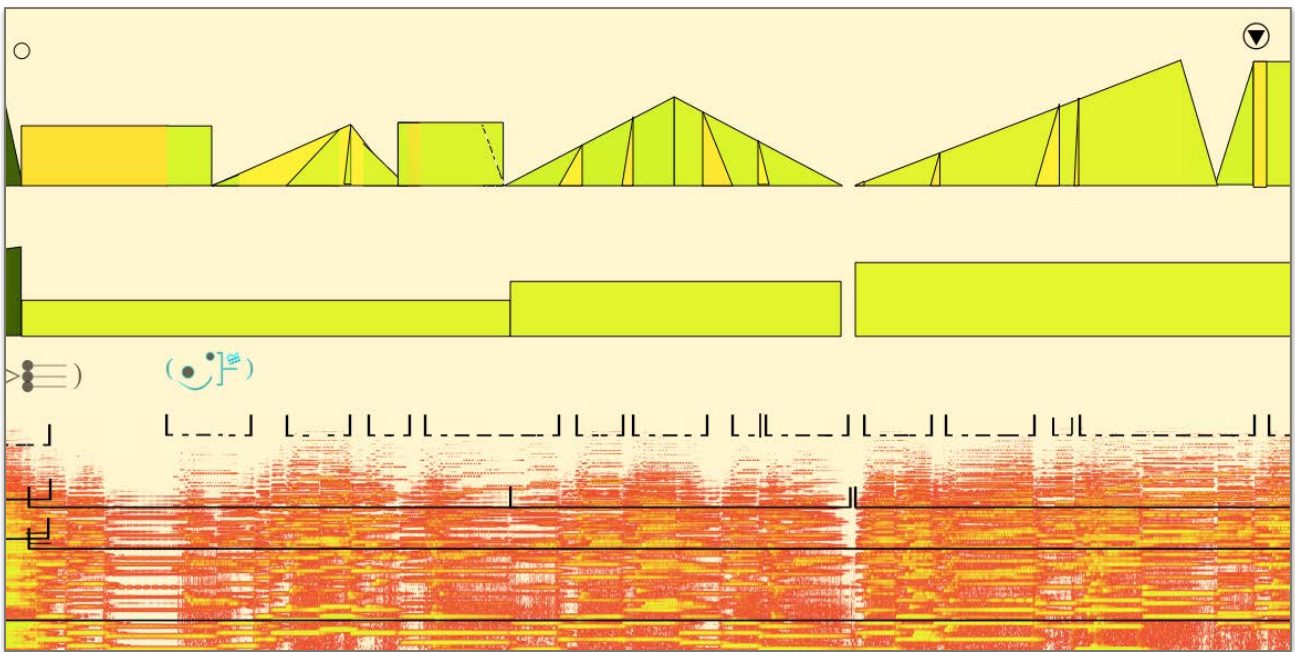

**Figure 4.5 - Draugsvoll 2' 30''-3' 34'', 1st video<sup>77</sup>**

The phrase- and sentence-field is marked with a hinged positioning (fig. 4.5), similar to the previous cluster and major dyad (fig. 4.3). There are four phrase-fields in the sentence-field, each perceived as a stable tendency gradually getting louder (fig. 4.5). The chorale, indicated as a pitched, sustained chord ( $L_1$ ), appears with a consonant harmonic color. The articulated motions of the chorale are illustrated as phrase-fields and the object-fields represent the composite sound-object, which establishes a dissonant fusion. This is indicated in the analysis with the color green. The trills play an important part of the harmonic tension, as the harmonies changes while the trill remains (first phrase-field). The performer articulates a rest between the second and third phrase-field, achieving a more subtle transition to the next phrase-field which is heard primarily as a forward-oriented tendency.

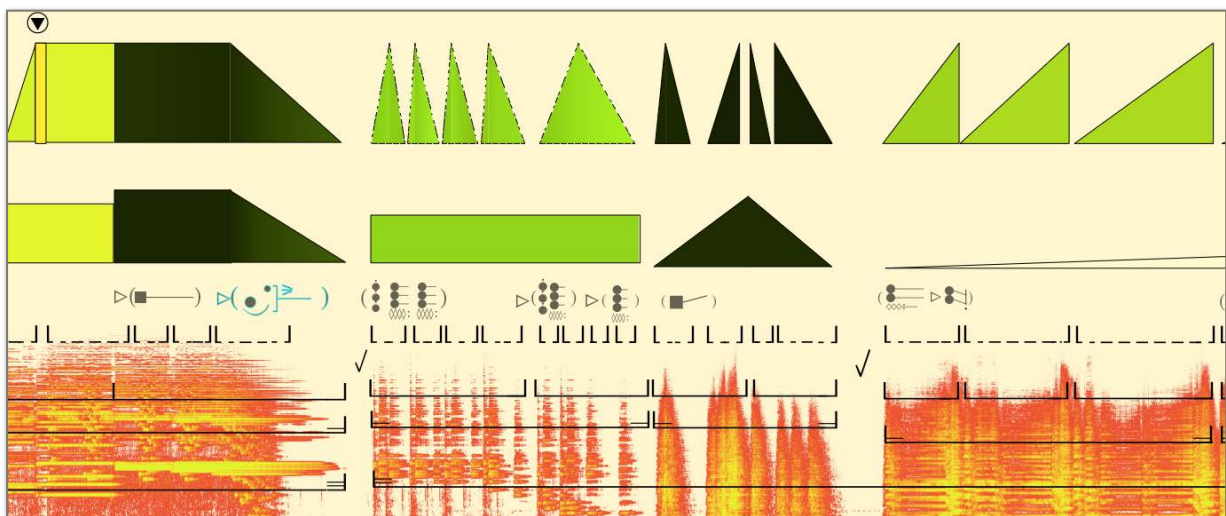

**Figure 4.6 - Draugsvoll 3' 30''-4' 48'', 1st video, <http://bit.ly/2prw7y4><sup>78</sup>**

<sup>77</sup> Ibid, page 3, second staff line - page 4, fourth staff line.

<sup>78</sup> Ibid, page 4, fourth staff line - page 6, first staff line.

The goal point represents a high register of pitch and the change in harmonic color creates a stronger tendency, as illustrated in the analysis as a higher static tendency of dark color (fig. 4.6). The composite sound-object repeats itself and declines to the lower timbral part of the register, while the bright cluster remains and fades away. This ends the first form-field of the piece.

The object-fields indicated in the aural analysis depicts a play with three homophonic textures; first an impulsive texture, then two sound-objects with sustained energy articulation with middle-fast dynamic gait (fluctuation). The lime-green color indicates a center between consonance and dissonance, and is recognized as a fusion of bitonality. The second phrase-field consists of a partitioning in patterns, illustrated by the disjunctions of the sound-objects, with varying silences between the textures. The faint dynamic tendency showed in the higher model depicts a tendency goal for each object-field. However, in the partitioning-segment, the tendency is directed in one broader dynamic form consisting of all the object-fields. The performer creates a dynamic structure which is not indicated in the score (fig. 4.7):



**Figure 4.7 - Score excerpt<sup>79</sup>**

The dynamic model that connects with the represented sustained cluster-glissandi indicates a black harmonic color (fig. 4.6). Similar, yet disparate, it relates to the cluster-glissandi heard before, but with the transformation to sustained energy articulation. The listener may perceive two articulated phrase-fields by the use of dynamics; one increasing tendency and one declining tendency.

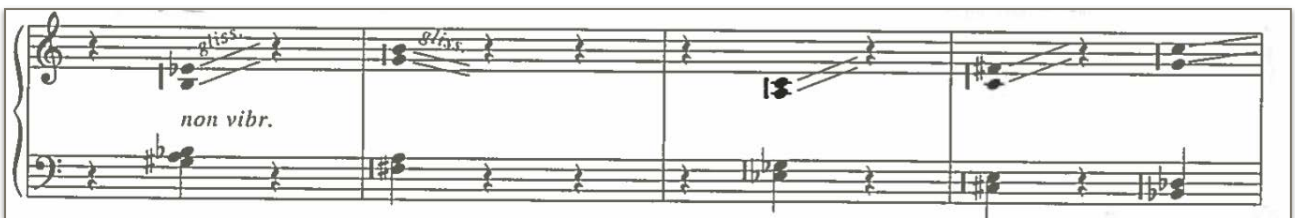

**Figure 4.8 - Score excerpt<sup>80</sup>**

<sup>79</sup> Ibid, page 5, second staff line.

<sup>80</sup> Ibid, page 5, fourth staff line.

The score does not imply any use of dynamics between the objects (fig. 4.8). Furthermore, the score illustrates a specific range of glissando which is shorter than what is perceived aurally.

The next sentence-field (the last field<sub>2</sub> in fig 4.6) consists of three phrase-fields, where the second and third field marks a recurrence and continuation of the previous motion. The vibrating tritone-interval, illustrated as a dyad with a middle-moderate dynamic gait that ends in a glissando, indicates a light dissonance of harmonic color. Each object-field and phrase-field expands in dynamics, thus establishing a lower model of increasing tendency between motions.

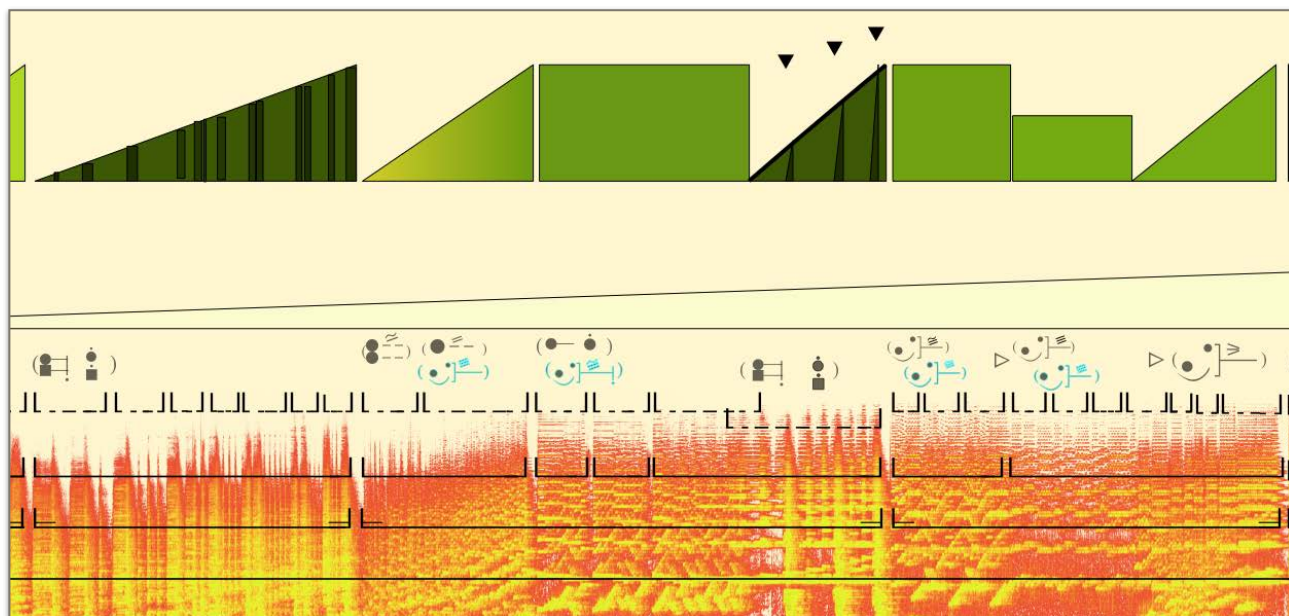

**Figure 4.9 - Draugsvoll 4' 48''-5' 57'', 1st video<sup>81</sup>**

The aural analysis depicts a continuance of increasing tendency in the lower model, as the next phrase-field (fig. 4.9 - first field<sub>1</sub>) proceeds with stronger articulation, higher dynamics and an accelerando. The object-field consists of two sound-objects with different articulations: The first object has sustained energy with a sharp ending, and the other is an impulse. The first sound-object is illustrated as a complex sustained texture with a pitch on top, representing a perceived chromatic motion of the texture. The darker shades of harmonic color indicate an occurrence of an articulated wider cluster.

The object-fields are interpreted as parts where the first sound-object (sustained energy, sharp ending) indicate the beginning of the object-field, while the other sound-object (impulse) indicate the ending. The perception of two impulses after each other, are conceived as parts of the same motion. This is an example of how the analysis reflects my aural interpretation.

The next phrase-field illustrates two sound-objects: first, two iterated homogeneous pitches,

<sup>81</sup> Ibid, page 6, second staff line - page 8.

second, a continuation of one iterated melodic motion, connected with a pitched composite sound (trill). The higher model in the aural analysis depicts a slight difference in harmonic color between these sound-objects (fig. 4.9). The directional forces showed in the lower model continues with faster operating figures than in the previous part.

The next section has three phrase-fields, where the second and third field marks a recurrence and continuation of the previous motion, similar to the development of the tritone interval at 04:27. Because of the recurrence, the listener perceives the phrase-fields as starting again and again. Therefore, the object-field and phrase-field have similar length. The sound-objects represents a pitched sound simultaneous with a composite sound in oblique ripple time, ending sharply with an impulse. The phrase-field is extended through the hinged positioning between the object-fields, as it continues to increase in dynamics. A similar sound-object previously heard at 04:49 appears; a complex sustained texture with a pitch ( $L_1$ ), resulting in a sharp ending and a textural impulse. The higher model is illustrated as an emphasized increasing tendency; it appears louder, brighter and longer compared to the previous sound-objects (04:48).

The object-fields (05:35 - fig.3.9) are defined by the first occurring composite sound-object as heard, while the other composite sound-object (blue) functions as an imitating counterpoint. Repetition of sound-objects contributes to the perception of a presence-oriented tendency indicated in the higher model. The next phrase-field dedicates a lower static-tendency and functions as a temporary containment in preparation for the next increasing tendency. The object-field illustrates a new motion of repetition in sound-objects; where previous sound-objects where oblique flutter time, is now transformed into regular flutter time, representing only the trill. The sentence-field ends with a louder and slower appearance of sound-objects, indicated with regular rit. in the aural analysis, establishing an overall increase of dynamic energy.

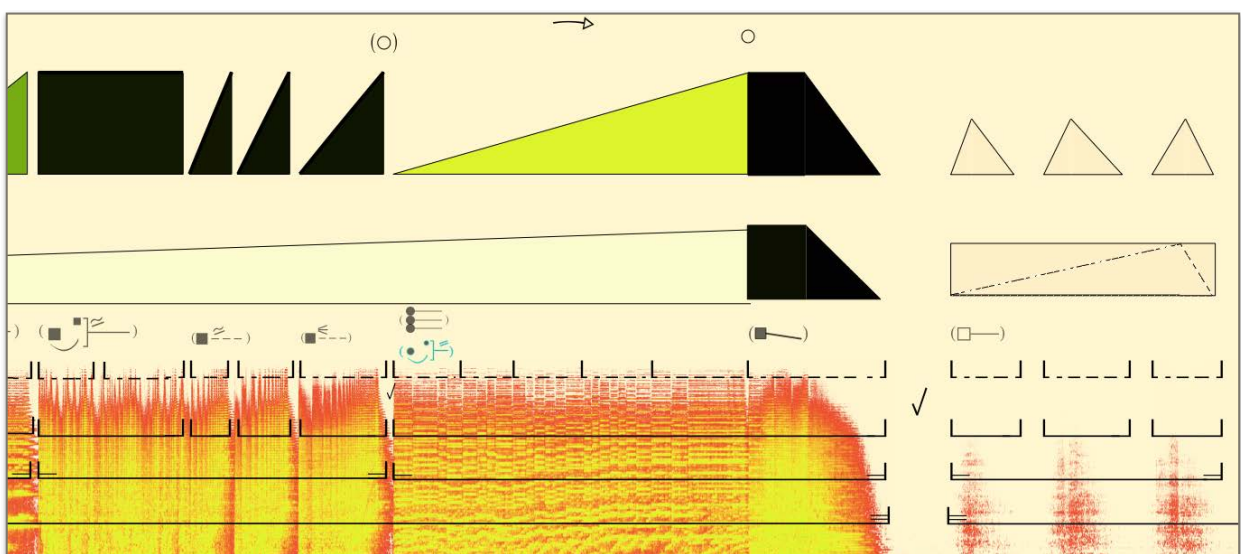

**Figure 4.10 - Draugsvoll 5' 57''-7' 12'', 1st video<sup>82</sup>**

The music reaches a new dynamic outburst with a new degree of harmonic complexity, for the first time in the second form-field (fig. 4.10). The first composite sound, indicated by the dark harmonic color, is identified with a similar rhythmic as the second phrase-field in figure 4.9 (05:07).

The second object-field (fig. 4.10) is a further development of the motion, which ends similarly as the first object-field. By this clearly rhythmical play, its dynamic functions is stable yet unpredictable. Thus, the sound-object is perceived as oblique. The second half of the first sentence-field (fig. 4.10) represents three motions of an iterated complex sound-object, which is connected with a directional tendency, indicated in the lower dynamic model. This is because it appears heavier, slower and more emphasized for each occurrence. With a rhythmical increase of intensity (*accelerando*) towards the higher register, it provides a perception of a blunted goal.

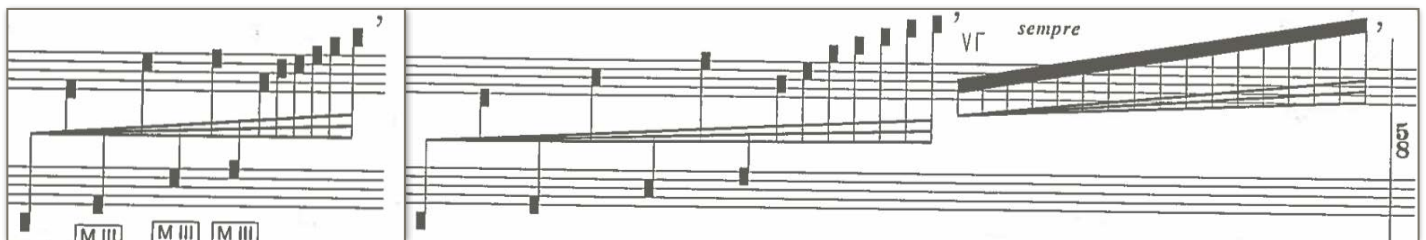

**Figure 4.11 - Score excerpt<sup>83</sup>**

Using these three steps of motion (fig. 4.11); 1) *motion*, 2) *motion prolonged*, 3) *motion expanded*, the composer creates an implicit aural possibility that creates a connecting directional tendency of the sound-objects. To that end, the pauses that separates the sound-objects will inevitably connect them as a directional-tendency, with the exception of extreme interpretations performed in ambient time.

The next extensive phrase-field (fig. 4.10) develops a prolongation of the goal, therefore attracts the directional forces further. The first reveal of consonance in the second form-field is expressed here by sustained chords, occurring with pitched composite sounds that alters the harmonic color and creates a fusional consonance indicated by the yellow-green (less dissonance, more consonance). The object-fields are interpreted through the major chord's direction of pitch and rhythmic relations, which represents the prominent function of field perception. Furthermore, the object-fields are gradually exploring higher ranges in register. The last object-field, illustrated as a

<sup>82</sup> Ibid, page 9 - page 11, first line staff.

<sup>83</sup> Ibid, page 9, third staff line - forth staff line.

goal, consists of a very complex harmonic color, as it aurally represent the thickest cluster in the piece. The ending of the goal point marks a declining tendency (fig. 4.10), similar to the ending of the goal point in the first form-field, although the dynamics are not specified in the score (fig. 4.12).

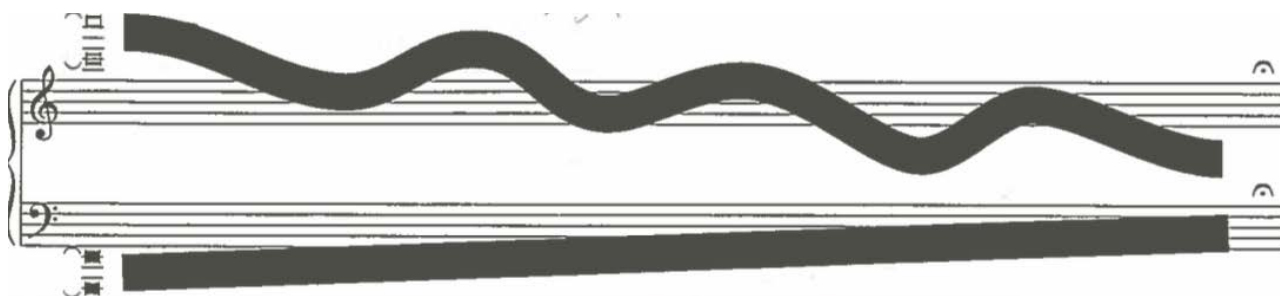
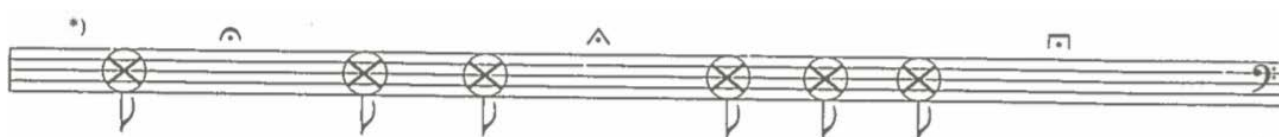

**Figure 4.12 - Score excerpt<sup>84</sup>**

Thus, the performer creates a connection of form-elements in a declining tendency, through the aural memory of the listener.

Air-sounds is perceived at the beginning of the third form-field (fig. 4.10), illustrated as unvoiced complex sounds. These sound-objects are provided by the air-button of the instrument.

The dynamic tendencies are shaped in a similar manner to previous sections, where phrase-fields appear with increasing and declining tendencies and are separated with noticeable silences. A connecting increasing tendency is indicated as a faint function within the presence-oriented primary function. The inconspicuous color inside the dynamic forms illuminates the lack of harmonic color from the sound-object as heard.

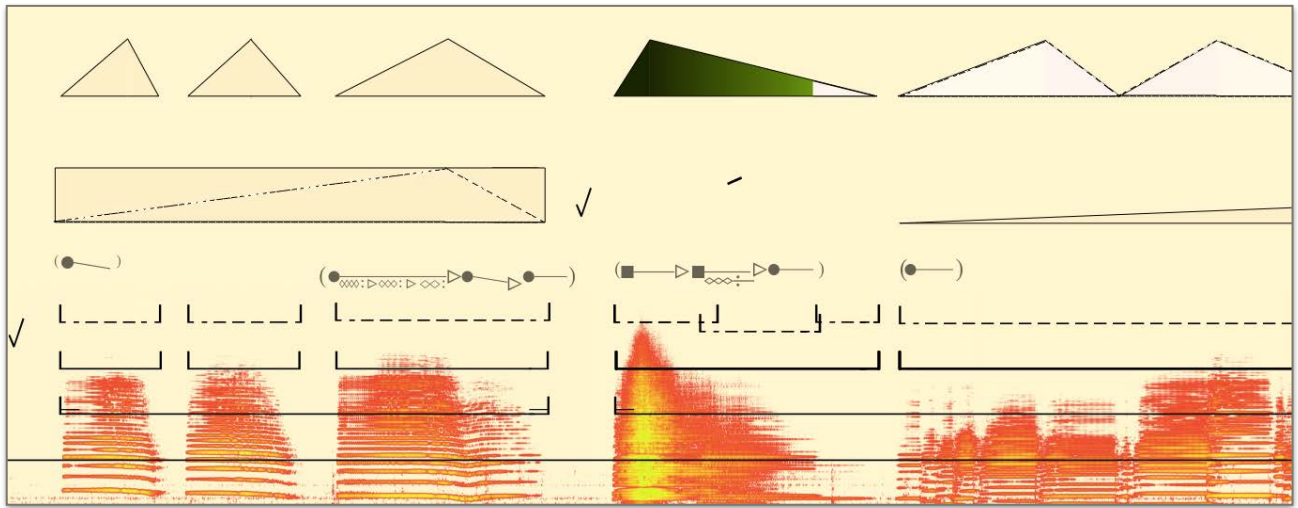

**Figure 4.13 - Score excerpt<sup>85</sup>**

The indications of the air-sounds in the score are enigmatic and are inevitable to be interpreted concerning dynamics, duration and articulation. To that end, if a performer plays this section with stable dynamics (and not in ambient time), it could be perceived with a faint-directional tendency, as each phrase consists of an additional air-sound, thus evolving with intensity.

<sup>84</sup> Ibid, page 10, fifth staff line.

<sup>85</sup> Ibid, page 11, first staff line.

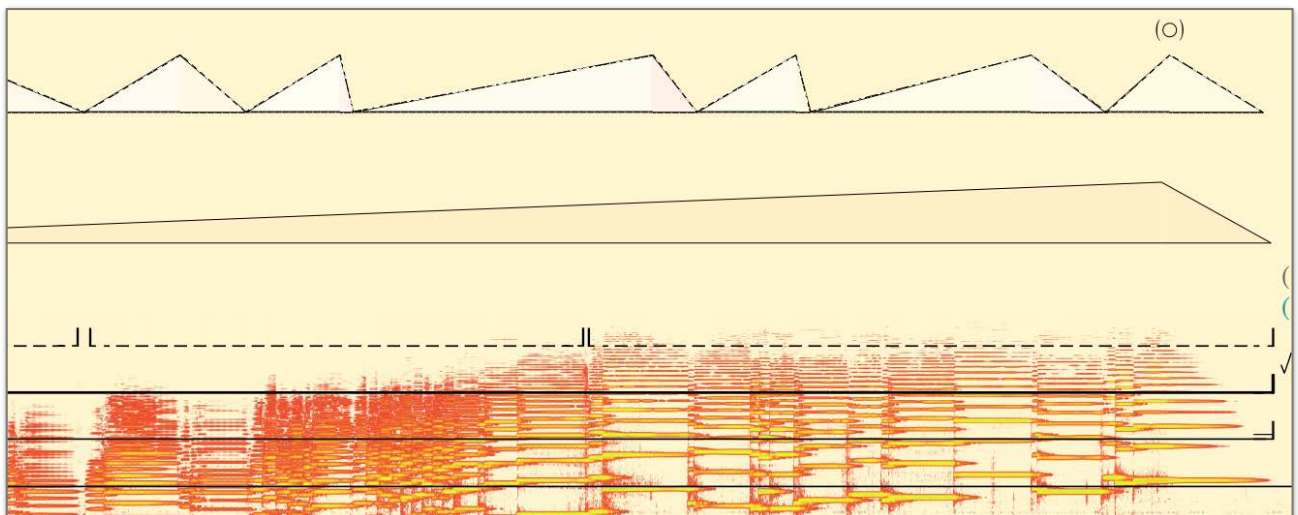

**Figure 4.14 - Draugsvoll 7' 12''-8' 33'', 1st video, <http://bit.ly/2prw7y4><sup>86</sup>**

The next sentence-field (fig. 4.14) appears in the same structure compared to the previous; three separate phrase-fields with a connecting faint tendency. The analysis depicts a sustained, variable pitched sound-object, that has not been previously heard. The third object-field illustrates a fluctuation in the sustained sound-object, transforming from fast to middle, to slow. It then transforms to the variable pitched sound heard before, but ends as a sustained sound-object.

The next phrase-field is interpreted in the aural analysis as a transition to the next, indicated as a bridged positioning. Within the emphasized phrase-field, the object-field are perceived as three parts; 1) the complex sustained texture (dark harmonic color), 2) fluctuation of texture (transformation to dark green), 3) one remaining, sustained pitch (lack of harmonic color).

The last phrase-field in the figure (4.14) is emphasized in the aural analysis as it follows a monophonic melody as heard, appearing as a cantabile passage.

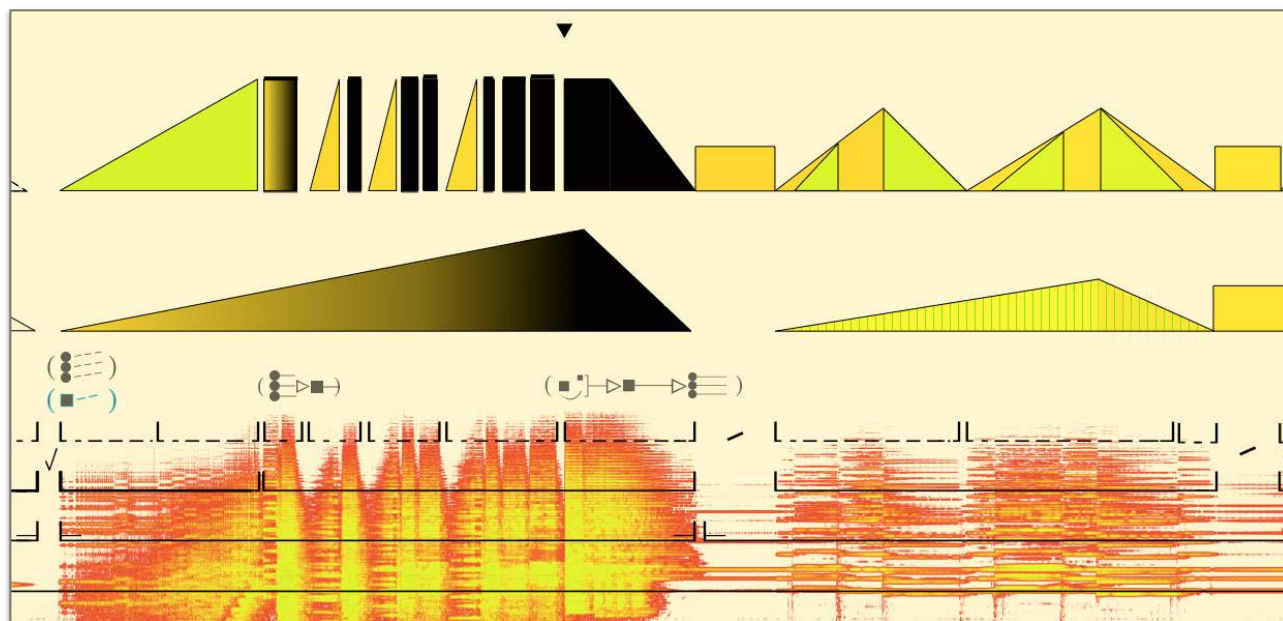

**Figure 4.15 - Draugsvoll 8' 33''-9' 44'', 1st video<sup>87</sup>**

<sup>86</sup> Ibid, page 11, second staff line - fifth staff line.

<sup>87</sup> Ibid, page 11, fifth staff line - ninth staff line.

The object-fields (fig. 4.15) are interpreted as parts through a larger change of pitch-intervals, articulations or rests, such as rounding off a coherent stream in legato. The performer is heard breathing preparing the next field, as if he was using his own voice. This intuition, as it is not specified as a musical sound-object, directs a perceptive designation of a new field. This segment is characterized by a large increasing tendency (indicated in the lower dynamic model), where the last pitched sound-object represents the designation of the phrase-field, illustrated as a blunted goal attainment.



**Figure 4.16 - Draugsvoll 9' 44''-10' 51'', 1st video<sup>88</sup>**

The yellow-green color illustrated in the upper model in the aural analysis (fig. 4.16), indicate prominent consonance. The iterated pitched chord is perceived as foreground and the iterated complex sound-object is heard as secondary. The phrase-field is emphasized, while the object-fields are interpreted through the major chord's direction of pitch and rhythmic relations.

The ascending-character, which is much established throughout the piece, continues towards an increasing direction of register. Moreover, the aural anticipation of a response is manifested through both ends of the harmonic-scale; clear consonance and large complexity. The cluster and the chord, that occurs simultaneous in first phrase-field (fig. 4.16), are opposed in consecutive motions in the second phrase-field (fig. 4.16). The dynamic motion is at its peak, but the increasing appearance of complex harmonies creates a connecting directional tendency. This is easily perceived in the analysis by comparing the dynamic forms with the object-fields, which indicates a consonant harmony at the beginning of an object-field and a complex texture at its end. This

<sup>88</sup> Ibid, page 12 - page 13, second staff line.



segment consists of additional complex textures for each object-fields, while the consonant texture remains as one (fig. 4.16). Based on this development of complexity (black), the analysis illustrates the lower model as one increasing tendency from consonant to increasingly more complex developments.

The next chord represents a transition with consonant harmonic color (fig. 4.16). The chords could be compared to the opening of the first chorale (02:30), where it moved in a diatonic direction (up, back, down) but now perceived with chromatics (up, back, down). The conscious memory of the listener may use these designations as a relation between the first form-field and the third.

The sound-object representing a transition is being held as a pedal point simultaneous with the following chordal motion. This creates a dissonance for every turn from its departure, indicated in the aural analysis from yellow to green. The segment is reflected in the object-fields and the process reoccurs after the first time. An increasing dynamic tendency connects both object-fields and descends at the end (fig. 4.16). The same transition reoccurs, leading to the next part.

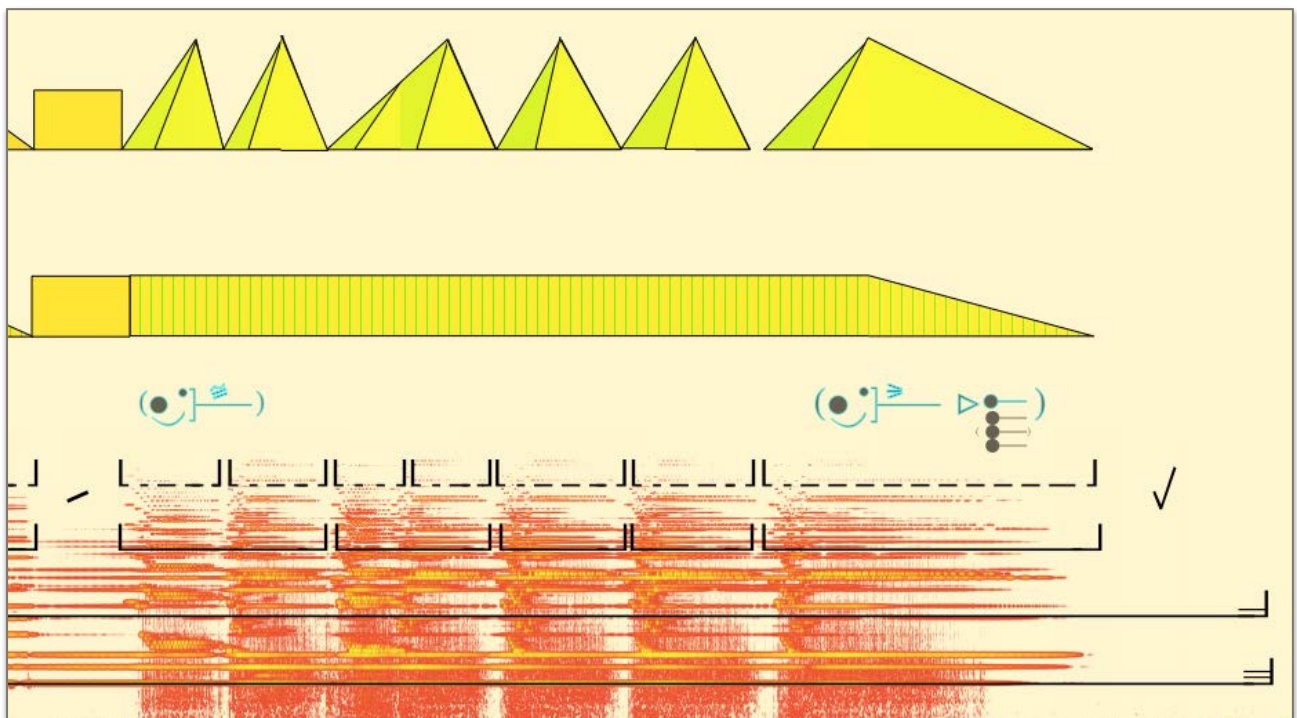

**Figure 4.17 - Draugsvoll 10' 51''-11' 39'', 1st video<sup>89</sup>**

The pitched composite sound-object (02:30) is recognized as it appears (fig. 4.17), creating a similar harmonic fusion as its previous occurrence (02:30). This may be interpreted as a coda for the listener, thus establishing a sign for destination. Unlike the previous section of these sound-objects (02:30), that consistently evolved new fusions of textures, each sound-objects do not

<sup>89</sup> Ibid, page 13, second staff line - fifth staff line.

change: the pitched chord is sustained and the composite sound-objects repeat its melodic pattern. These motions are first separated object-fields, then connected simultaneous with the phrase-fields (fig. 4.17).



**Figure 4.18 - Score excerpt<sup>90</sup>**

The excerpt (fig. 4.18) presents another example of an unidiomatic paradox, where the score does not require a soft ending; the trill does not end and the harmony does not close. But the music often does require an interpretation of a soft ending, if the performer wants to provide a certain calmness at the end. It is vulnerable to create the trill with high pitch and low dynamics on the accordion, as it easily produces unwanted noise from the press of the buttons. The performer creates a ritardando and ends with a creation of harmony between the two previously separated sound-objects, making a larger chord. Doing this makes it much easier to restrain the declining tendency of the high pitch without any unwanted noise, and it is a soft transition to the outcome of silence. As seen in the bars before the ending (fig. 4.18), each phrase of the melodic voice has a note after the trill, which is not connected of the phrasing-bow. Thus, it could be played or rested upon before proceeding, and could be the reason of which the performer chooses to end the piece on the f-sharp.

<sup>90</sup> Ibid, page 13, fifth staff line.

### 4.3 Form structures - The fundamental synopsis of the piece

Extensive details of the analysis have been observed, defined and presented carefully in the recent text. As a next step, the totality of the piece constituted by larger forms will be presented as a form-analysis of the piece. By reducing parts of the analysis, leaving out the higher level-dynamic model, object-fields and other more technical depictions, makes it more practical to see the fundamental structure of the analysis.

The observer is left with the following signs of analysis:

- larger dynamic tendencies  
(indicated by the lower model, while the higher model indicate dynamic form)
- condensation of successive harmonicities  
(indicated by harmonic colors)
- summary of developments in sound-objects  
(indicated by the signs of spectromorphology)
- phrase-fields, sentence-fields and form-fields

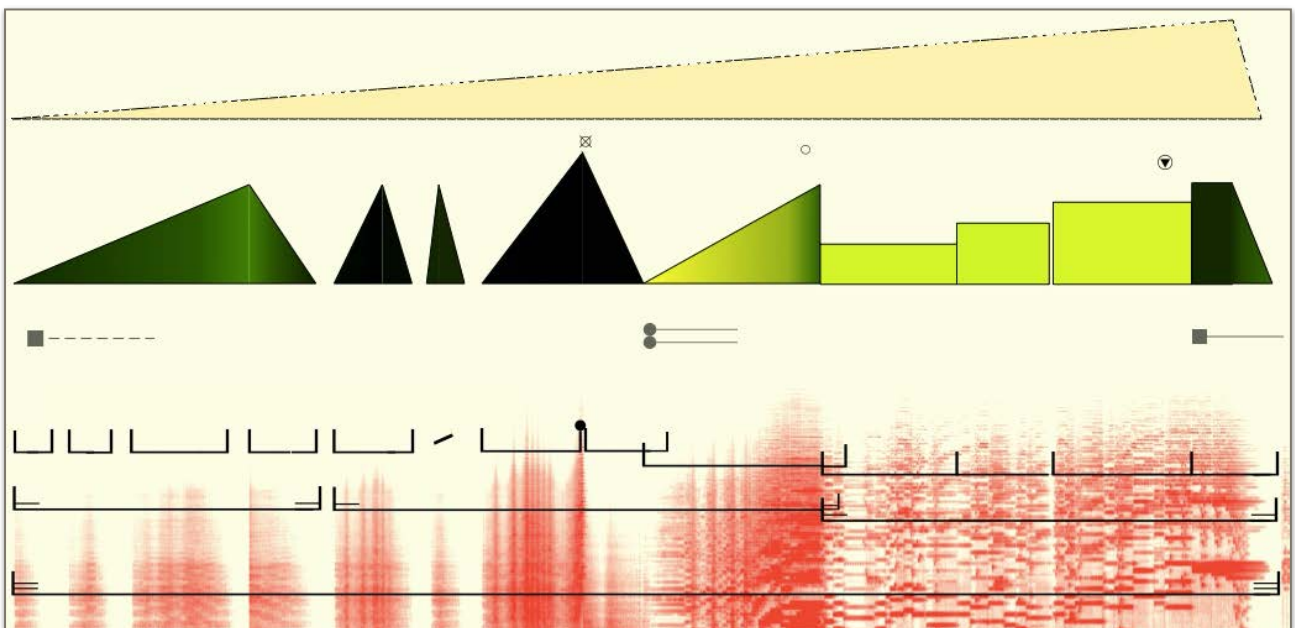

**Figure 4.19 - First form-field (Draugsvoll) 0' 01''-3' 53''**

A transformation of the sound-objects occurs in the first form-field, from the complex iterated texture, to the pitched sustained texture (fig. 4.19). This change occurs in the middle of the form-field and second sentence-field. At the end of the third sentence-field, the sound-object returns to a complex, but sustained texture. Transformations of harmonic colors are visible, between the

dichotomy of sound-objects ( $L_1$ ). The successive structures of dynamic models suggests an increasing tendency of form (fig. 4.19 - higher dynamic model).

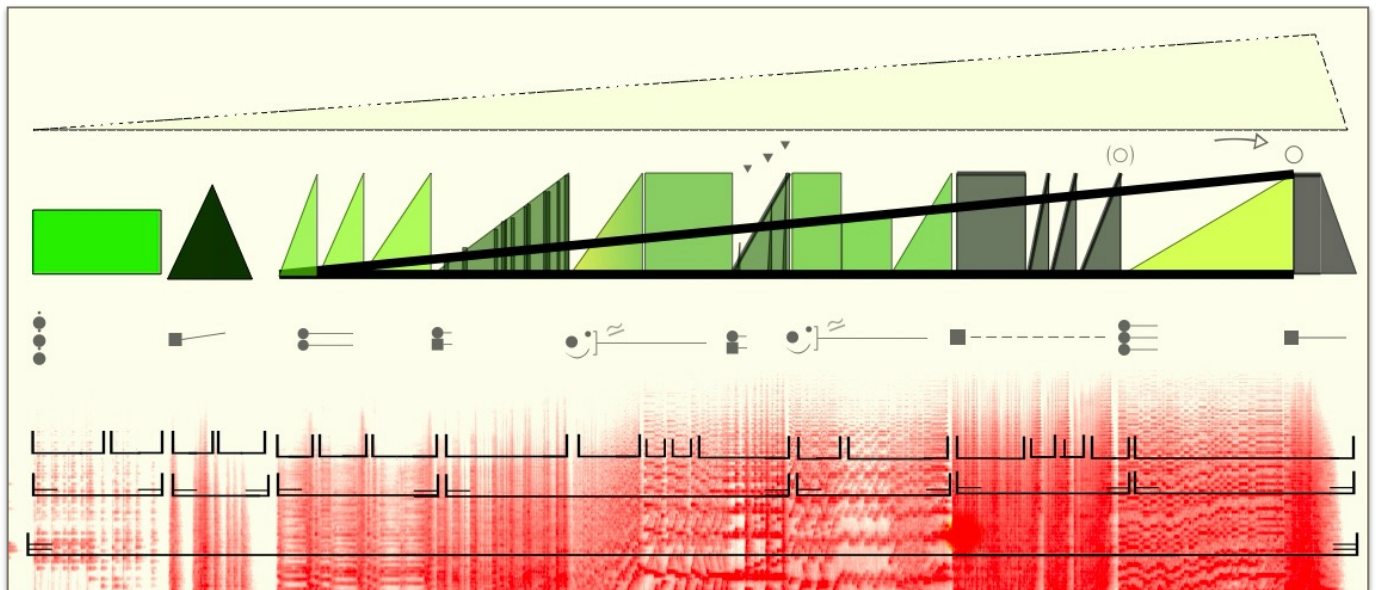
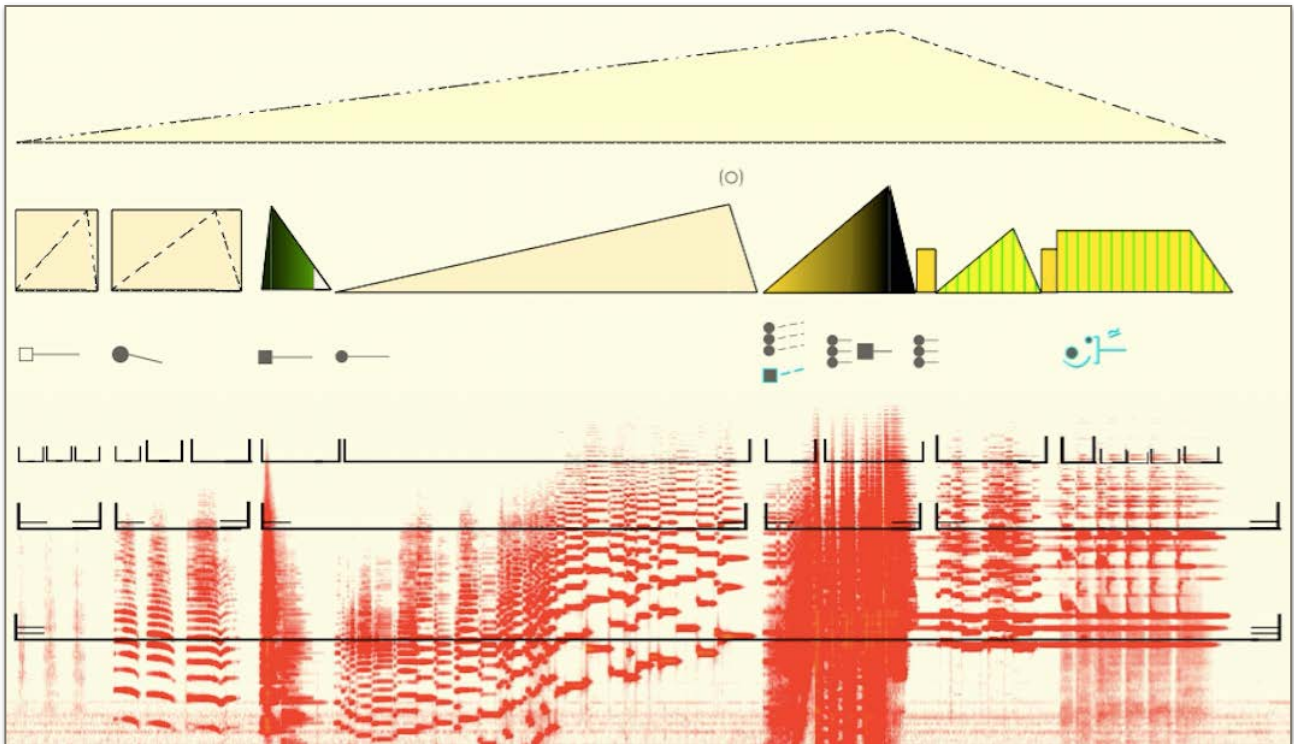

**Figure 4.20 - Second form-field (Draugsvoll) 3' 53''-6' 51''**

New sound-objects are introduced (fig. 4.20) and the second form-field consist of a broader complications of elements. The illustrated sound-objects are far more detailed in this summary, compared to the first form-field; the music has a less accessible designation of transformation in the occurring sound-objects ( $L_1$ ). Nevertheless, the play between complex and pitched objects consists of many opposed elements:

first example being  $\begin{matrix} \bullet \\ \bullet \\ \bullet \end{matrix} \triangleright \blacksquare \triangleright \begin{matrix} \bullet \\ \bullet \\ \bullet \end{matrix}$ , or the last example being  $\blacksquare \text{---} \triangleright \begin{matrix} \bullet \\ \bullet \\ \bullet \end{matrix} \begin{matrix} \text{---} \\ \text{---} \\ \text{---} \end{matrix} \triangleright \blacksquare \text{---}$ .

The third dynamic-model looks peculiar; it consists of a large, emphasized tendency involving smaller dynamic tendencies of the original analysis. While being an unusual figure, it is used to limit the reduction of structural transformations of harmonic complexity. However, on this section one may easily notice a gradual expansion of harmonic complexity, with the exception for the ending-segment of consonance, before reaching a large complexity. This last increasing tendency with consonance functions as a suspension of the goal ( $(\circ) \text{---} \triangleright \circ$ ), as it further directs the listener until it reaches a designated ending with large complexity. A similar increasing tendency of form can be made of these successive dynamic models (fig. 4.20 - higher dynamic model).



**Figure 4.21 - Third form-field (Draugsvoll) 6' 51''-11' 39''**

If the second form-field is regarded as an advancement of sound-object-transformations, then the third form-field can be considered a retrogression.<sup>91</sup> The first half of the analysis depicts a development of different monophonic sound-objects (fig. 4.21);

1. Field<sub>2</sub> : *air-sounds* marked as unvoiced complex sounds (□ —)
2. Field<sub>2</sub>: *tone glissandi* marked as variable, sustained pitched sound (● )
3. Field<sub>2</sub> : 1) *cluster* marked as stable, sustained complex texture (■ —), 2) *interval-based recitative* marked as stable, sustained pitched sound (● —).

The monophonic sound-objects creates an absence of harmonic, with an exception of the texture.

Furthermore, a certain confrontation of dichotomic sound-objects emerge; the complex texture and the pitched chord. The harmonic colors depict a development from consonance to complexity, because the chords are heard as more prominent than the simultaneous cluster. A further separation of the opposites occur ( :≡▸ ■ — ), with a recurring emphasis of complex textures ( :≡▸ ■ —▸ ■ — ). However, the last sentence-field illustrates the pitched chord as a remaining sound-object. This is illustrated with yellow and light-green marks, which represents a slight

<sup>91</sup> Definition: the process of returning to an earlier state, Oxford Dictionary of English.

dissonant tension. The last compound sound-object (●<sup>]</sup>←) requires a mention in the aural analysis, as it receives a special attention from the listener. This means that the pitched chord is heard as a background to the composite sound-object, appearing as designated end. This is a contrast to the quite similar ending of the first form-field, which ended with a complex texture. Given that there are no harmonic or melodic transformations in the ending, meaning that both the chord and the melodic pattern repeats and does not change, the composite sound-object is illustrated as the last timbral sign in the form-analysis. The declining calmness of dynamics in the last sentence-field reduces the previously established increasing tendency of dynamic form, and provides a more calmer ending of the third form-field (fig. 4.21 - higher dynamic model).

# Form analysis of *De Profundis* *Geir Draugsvoll (1992)*

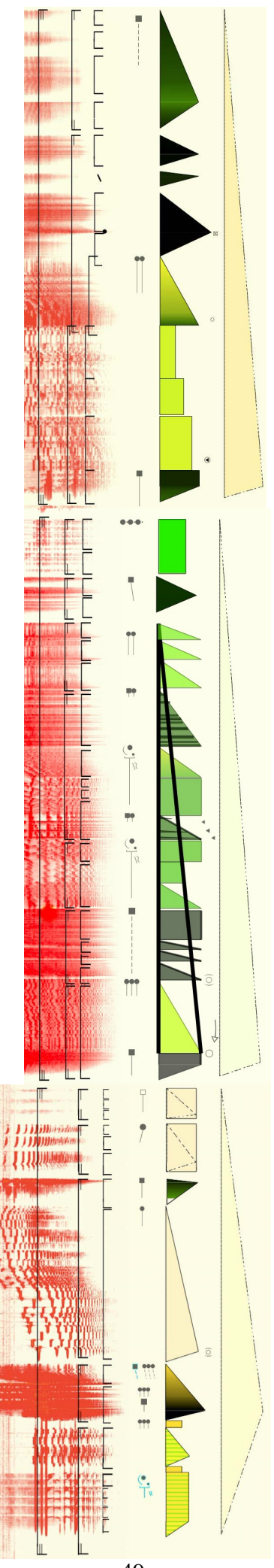

#### 4.4 Introduction to exosemiotics as-heard

I will seek a phenomenological approach into the field of musical semiotics presented by Thoresen as an approach called *Exosemiotic of music-as-heard*. The term *exosemiotic* or *exosemantic* is referred in this context to the way music is associated with entities beyond its own material and inherent structure. An oppositional approach is a taxonomic description of entities that would be identified as endosemantic.<sup>92</sup>

Endosemantic elements will serve as a description of the *signifier* (the perceptible sign) that will associate an exosemantic *signified* (the hidden meaning of the sign). These are two aspects out of three in total, which consists inside the definition of a musical sign; the manifest aspect (signifier), the hidden aspect (signified) and the link between them (the *semiosis*). Thoresen further defines semiosis as the nature of the mental act that joins the signifier and the signified, and can be identified as being the listening intentions that imbue what we hear with meaning. Mankind is creators that transcend the immediate percept in order to associate meanings that are the matter of the mind. Man is distinct from the animal by its mastery of intricate sign systems and languages, and the life of mankind could be seen as an endless process of interpreting reality through perception and thinking. The intentional act that lies under the creation of meaning is what defines semiosis.<sup>93</sup>

Three primary semioses will be used as listening intentions; *causal inference* (abbreviation: INFER), *connotation* (abbr. CONNOT) and *comparison* (abbr. CMPAR). The primary semiosis casual inference can be described as "reason[ing] to the conclusion that something is, or is likely to be, the cause of something else".<sup>94</sup> Comparison as a semiosis concerns the connection of comparing a signifier, such as a perceived sound, with something outside the music itself; a descending minor third interval, may be compared to a cuckoo. If a listener interprets a musical imitation of symptoms of feelings, the semioses is often recognized as CMPAR and INFER. This is because we have to deal with a phenomenon that is similar to the symptoms caused by the feeling.

In the article *Exosemantic Analysis of music-as-heard*, Thoresen uses the term *association*, but in this context it is replaced with connotation. This term is preferred as it represents the associated or secondary meaning of a word or expression in addition to its explicit or primary meaning. A possible connotation of 'home' can be 'a place of warmth, comfort and affection'.

---

<sup>92</sup> Thoresen, *Exosemantic Analysis of music-as-heard*, Meaning and Meaningfulness in Electroacoustic Music, (Stockholm, June 2012), 2.

<sup>93</sup> Thoresen, *Emergent musical forms*, 95.

<sup>94</sup> Encyclopedia Britannica, s.v. "causal inference", 06.05.2017. <https://www.britannica.com/topic/causal-inference>.



The secondary semiosis is a further specification of the circumstantial process of the interpretation. Thus, a degree of conventionality of the sign will be indicated, spanning from full openness (a new sign which is not defined) to clearly defined semiosis (such as a national anthem).<sup>95</sup> In the semiotic model we will use four different categories; open interpretation (F<sub>0</sub>), conventional interpretation (F<sub>1</sub>), coded interpretation (F<sub>2</sub>) and opaque interpretation (F<sub>3</sub>). The secondary semiosis opens the interpretation of signs to a process of historical change, as new things tend to be stylized, coded and eventually taken for granted. One example is the interpretation of the swastika-symbol, which has been an important symbol for Hindus and Buddhists in India and other Asian countries for many thousands of years, before it became used of one of the most hated men on Earth and has since been highly stigmatized because of its association with Nazism.

Thoresen addresses a diagram to depict the constitution of musical signs, as presented in the next figure (4.22). The three levels of articulation (sound-object, compound sound-patterns and form-building-patterns) are represented to categorize different manifest aspects (signifier).

<b>Signified:</b> (to be described in each case)	<b>S E M I O S E S</b>	<b>Primary semioses:</b>	<b>Secondary semiosis/ Fixity of Interpretation:</b>	
<b>Signifier levels:</b>			F <sub>0</sub>	Open interpretation
Level 1		Causal Inference	F <sub>1</sub>	Conventional/habitual interpretation
Energy    Substance    Shape		Connotation	F <sub>2</sub>	Coded (or lexical) interpretation
Level 2		Comparison	F <sub>3</sub>	Opaque interpretation (original meaning forgotten)
Energy    Substance    Shape				
Level 3				
Energy    Substance    Shape				

**Figure 4.22 - The constitution of musical signs<sup>96</sup>**

#### **4.5 Sound-objects, harmonicities and dynamic forms**

Three musical elements will be considered as primary signifiers in this exosemantic interpretation of Geir Draugsvoll's performance of *De Profundis*; the consideration of character-relations between sound-objects (L<sub>1</sub>), the consideration of harmonic color (L<sub>2</sub>) and the dynamic forms (L<sub>3</sub>) created by the performer. The perceived meaning of these musical elements depends on whether one intends a

<sup>95</sup> Thoresen, *Exosemantic Analysis of music-as-heard*, 3.

<sup>96</sup> Ibid.

spiritual interpretation, or simply a portrayal of the musical elements as gestures without a semantic frame of reference. I intend to provide examples of both, though coded interpretations (F<sub>2</sub>) in relation to spiritual symbolism will be of first concerns, as it is implied through the title of the piece and the influential intentions from the composer's personal beliefs.

#### 4.6 Exosemantic indications

The next model depicts the process of this artistic research.

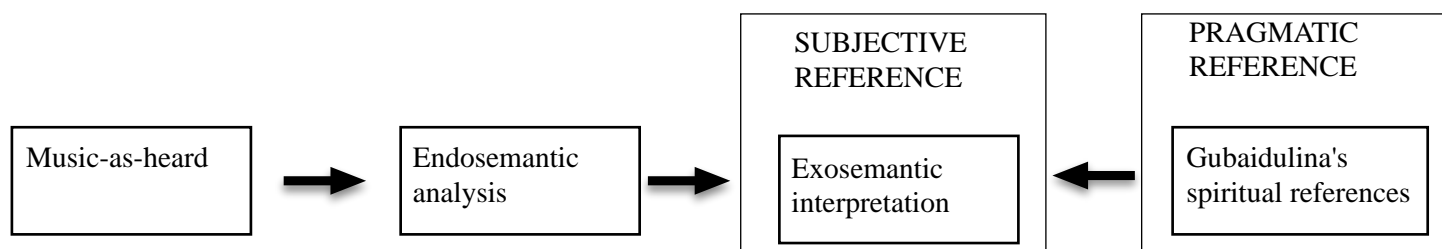

Perceiving the music-as-heard is the groundwork to the next stage; endosemantic analysis of the material. Both of these stages are reached and we are currently positioned at the starting point of the exosemantic interpretation. This stage consists of connections between the endosemantic analysis and the spiritual references of Gubaidulina. These references are exosemantic impulses and indications based on the influence of Gubaidulina's spiritual world, introduced in her biographical chapter.

#### 4.7 Psalm 130

A further essential reference of exosemantic indications is the text of Psalm 130, which relates to the title of the interpreted work. An exosemantic interpretation of a musical piece is certainly conditioned by subjective references; therefore, this text may be used as a pragmatic reference and ambition as it is targeted by the composer herself. The intention of interpretation in this context is justified, in some measures, with the text as an authentic source of exosemantic indications.

**Psalm 130** - New International Version (NIV)<sup>97</sup>

*A song of ascents.*

1 Out of the depths I cry to you, Lord;

2 Lord, hear my voice.

Let your ears be attentive

to my cry for mercy.

3 If you, Lord, kept a record of sins,

Lord, who could stand?

4 But with you there is forgiveness,

so that we can, with reverence, serve you.

5 I wait for the Lord, my whole being waits,

and in his word I put my hope.

6 I wait for the Lord

more than watchmen wait for the morning,

more than watchmen wait for the morning.

7 Israel, put your hope in the Lord,

for with the Lord is unfailing love

and with him is full redemption.

8 He himself will redeem Israel

from all their sins.

---

<sup>97</sup> Holy Bible, New International Version®, collected 22/04 at <https://www.biblegateway.com/passage/?search=Psalm+130>.

### 4.8 Exosemiotic analysis of *De Profundis*

The numbers inside the parenthesis indicate the seconds and minutes of the aural analysis.

[0' 02"]

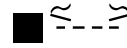

Signifier:	Primary semiosis	Secondary semiosis	Signified
Iterated stable sound (L <sub>1</sub> )	CMPAR+INFER	F <sub>2</sub>	Anxiety, Introversion
Complex sound in low register (L <sub>1</sub> )	CMPAR+CONNOT	F <sub>2</sub>	Depths, Sin
Oblique accel./rit. (L <sub>1</sub> )	CMPAR	F <sub>2</sub>	Sermoning

[2"-58"]



Signifier:	Primary semiosis	Secondary semiosis	Signified
Slightly brighter harmonicities (L <sub>2</sub> )	CMPAR + INFER	F <sub>2</sub>	Desire of disentanglement
Increasing dynamic tendencies (L <sub>3</sub> )	CMPAR + CONNOT	F <sub>2</sub>	Effort of calling/ crying

[1" 01"]



Signifier:	Primary semiosis	Secondary semiosis	Signified
Variable sound(L <sub>1</sub> )	CMPAR + INFER	F <sub>2</sub>	More extrovert, Calling



[1" 01"-1" 15"]

<b>Signifier:</b>	<b>Primary semiosis</b>	<b>Secondary semiosis</b>	<b>Signified</b>
Related tendencies (L <sub>3</sub> )	CMPAR + INFER	F <sub>2</sub>	Calling to the Lord, More intensity

[1" 18"]

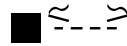

<b>Signifier:</b>	<b>Primary semiosis</b>	<b>Secondary semiosis</b>	<b>Signified</b>
Recurring stable sound-object (L <sub>1</sub> )	CMPAR + INFER	F <sub>1</sub>	Back to the beginning, Repudiation

[1" 27"-2" 29"]

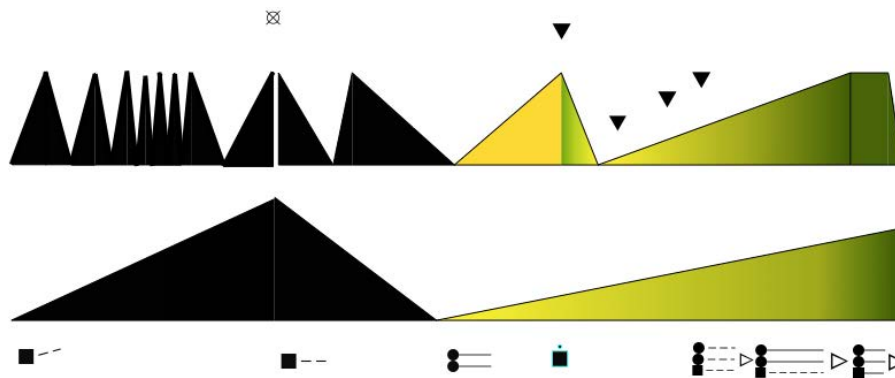

<b>Signifier:</b>	<b>Primary semiosis</b>	<b>Secondary semiosis</b>	<b>Signified</b>
Variable sound (L <sub>1</sub> ) + emphasized quicker tendencies (L <sub>3</sub> )	CMPAR+INFER	F <sub>2</sub>	More extrovert, calling to Lord
Stable sound (L <sub>1</sub> ), declining tendency (L <sub>3</sub> )	CMPAR+CONNOT	F <sub>2</sub>	Renunciation
Dyad (L <sub>1</sub> ), consonance (L <sub>2</sub> )	CMPAR+INFER +CONNOT	F <sub>2</sub>	Light, Hope of forgiveness
Gradual integral texture of both pitch and clusters (L <sub>1</sub> )+(L <sub>2</sub> )	CMPAR+INFER +CONNOT	F <sub>2</sub>	Hope and fear, Longing of redemption

[2" 30"]

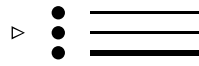

Signifier:	Primary semiosis	Secondary semiosis	Signified
Pitched chord(triad)(L <sub>1</sub> )	CMPAR+INFER +CONNOT	F <sub>2</sub>	Joy, Reverence

[2" 38"]



Signifier:	Primary semiosis	Secondary semiosis	Signified
Composite sound-object (L <sub>1</sub> ) + Dissonance with chord (L <sub>2</sub> )	CMPAR + CONNOT	F <sub>2</sub>	Bird song, Morning

[2" 30"-3" 53"]

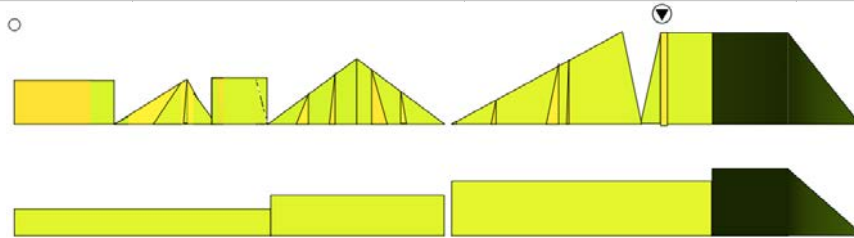

Signifier:	Primary semiosis	Secondary semiosis	Signified
Increasing tendency (L <sub>2</sub> +L <sub>3</sub> )	CMPAR + CONNOT	F <sub>2</sub>	Crying for mercy
Complex texture in high register (L <sub>1</sub> +L <sub>2</sub> )	CMPAR + INFER	F <sub>2</sub>	No redemption yet, Sinfulness

[3" 54"-4" 58"]

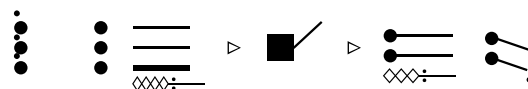

Signifier:	Primary semiosis	Secondary semiosis	Signified
Impulse + moderate fast dynamic gait (L <sub>1</sub> )	CMPAR+INFER	F <sub>2</sub>	Shivering, Whole being waits
Sustained variable (L <sub>1</sub> )	CMPAR+INFER	F <sub>2</sub>	Wondering, Awe
Stable dyad + moderate/middle dynamic gait + variable sharp onset (L <sub>1</sub> )	CMPAR+INFER	F <sub>1</sub>	Calling, Tense, Collapse

[3" 54"-4" 47"]

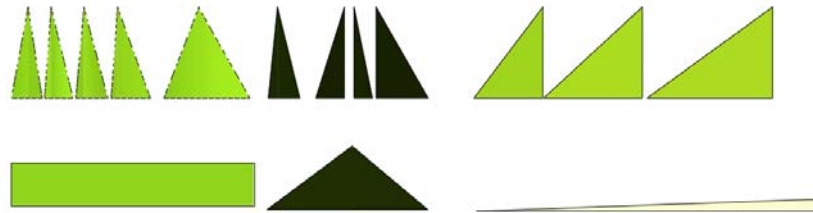

Signifier:	Primary semiosis	Secondary semiosis	Signified
Silence (L <sub>1</sub> )	CMPAR+INFER +CONNOT	F <sub>2</sub>	Abandoned, Waiting
Shorter tendencies (L <sub>3</sub> )	CMPAR+INFER	F <sub>1</sub>	Careful, Indecisive
Increasing tendencies (L <sub>3</sub> )	CMPAR+INFER	F <sub>1</sub>	Initiative, Eager

[4" 48"]



Signifier:	Primary semiosis	Secondary semiosis	Signified
Stable energy + impulse (L <sub>1</sub> )	INFER+CONNOT	F <sub>2</sub>	Calling, Collapse

[5" 05"-5" 27"]

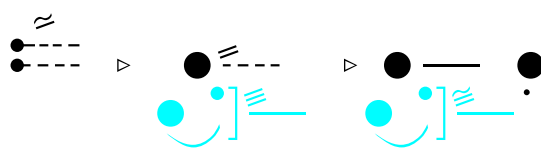

Signifier:	Primary semiosis	Secondary semiosis	Signified
Iterated homophony + oblique ripple time (L <sub>1</sub> )	CMPAR+CONNOT	F <sub>1</sub>	Unified, Rushing
Regular iterated pitch + trills (L <sub>1</sub> )	CMPAR+INFER	F <sub>1</sub>	Persistent, Distressed
Sustained melody+ oblique ornaments + sharp onset (L <sub>1</sub> )	CMPAR+INFER	F <sub>1</sub>	Aspire, Eruption, Collapse

[5" 28"]

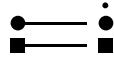

Signifier:	Primary semiosis	Secondary semiosis	Signified
Recurring object in higher register: Stable energy + impulse (L <sub>1</sub> )	CMPAR+INFER	F <sub>2</sub>	Continuing his calls and collapses to the Lord

[4" 48"-5" 35"]

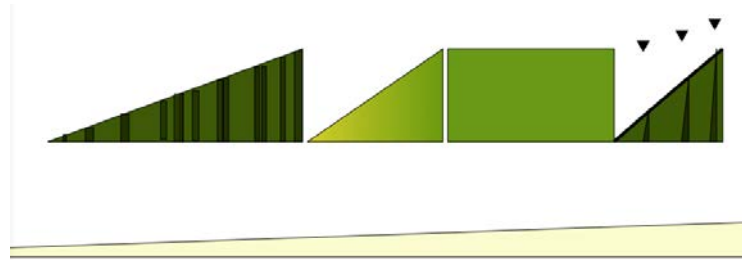

Signifier:	Primary semiosis	Secondary semiosis	Signified
Longer tendency-lower model (L <sub>3</sub> )	CMPAR + CONNOT	F <sub>2</sub>	Struggle for redemption

[5" 36"-5" 56]



Signifier:	Primary semiosis	Secondary semiosis	Signified
Imitating melodic patterns + trills (L <sub>2</sub> )	CMPAR+CONNOT	F <sub>2</sub>	Repeating message to the Lord, Sweating
Heterophony, trills (L <sub>2</sub> )	CMPAR+INFER	F <sub>2</sub>	Unrestrained, Sweating
Rit.	INFER+CONNOT	F <sub>2</sub>	Dilapidation, Despair

[5" 57"-6" 19"]





<b>Signifier:</b>	<b>Primary semiosis</b>	<b>Secondary semiosis</b>	<b>Signified</b>
Composite complex sounds (L <sub>1</sub> )	CONNOT	F <sub>1</sub>	Disorder, Untidiness
Iteration (L <sub>1</sub> )	CMPAR+INFER	F <sub>1</sub>	Distinctive, Focus
Accel. (L <sub>1</sub> )	CMPAR+INFER	F <sub>1</sub>	Unmistakable, Targeted

[6" 20"]

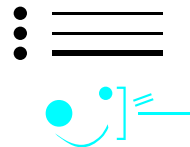

<b>Signifier:</b>	<b>Primary semiosis</b>	<b>Secondary semiosis</b>	<b>Signified</b>
Major chord(L <sub>1</sub> )	CONNOT	F <sub>2</sub>	A sign of the Lord, Belief, Hope
Melodic pattern (L <sub>1</sub> ) + dissonance (L <sub>2</sub> )	CMPAR + CONNOT	F <sub>2</sub>	Message, Agony

[6" 42"]



<b>Signifier:</b>	<b>Primary semiosis</b>	<b>Secondary semiosis</b>	<b>Signified</b>
Complex descending sound (L <sub>1</sub> )	CMPAR+INFER	F <sub>2</sub>	Agony, Disintegration

[5" 35"-6" 50"]

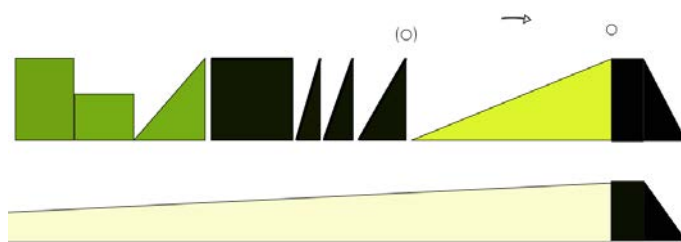

<b>Signifier:</b>	<b>Primary semiosis</b>	<b>Secondary semiosis</b>	<b>Signified</b>
Complex harmonicity (L <sub>2</sub> )	CMPAR+INFER	F <sub>2</sub>	Peak of agony
Consonance (L <sub>2</sub> )	CMPAR+CONNOT	F <sub>2</sub>	Connection with the Lord
Ends with complexity (L <sub>2</sub> )	CMPAR+INFER	F <sub>2</sub>	Drained, Exhausted

[6" 55"-7" 27"]



Signifier:	Primary semiosis	Secondary semiosis	Signified
Unvoiced element (L <sub>1</sub> )	CMPAR+CONNOT	F <sub>2</sub>	Breathing, Left alone
Tone glissando (L <sub>1</sub> )	CMPAR+INFER +CONNOT	F <sub>2</sub>	Worried, Deserted
Vibrating pitch (L <sub>1</sub> )	CMPAR +INFER	F <sub>2</sub>	Shivering, Lonesome
Stable pitch (L <sub>1</sub> )	CMPAR +INFER	F <sub>2</sub>	Precarious

[6" 55"-7" 27"]

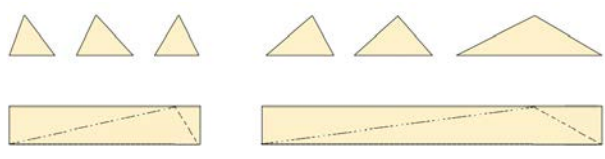

Signifier:	Primary semiosis	Secondary semiosis	Signified
Faint direction of tendencies (L <sub>3</sub> )	CMPAR+INFER	F <sub>2</sub>	Questionable, Disoriented

[7" 50"]



Signifier:	Primary semiosis	Secondary semiosis	Signified
Complex texture (L <sub>1</sub> )	CMPAR +INFER	F <sub>2</sub>	Pain
Pitched sound (L <sub>1</sub> )	CMPAR+CONNOT	F <sub>0</sub>	Echoed reflection

[8" 07"]

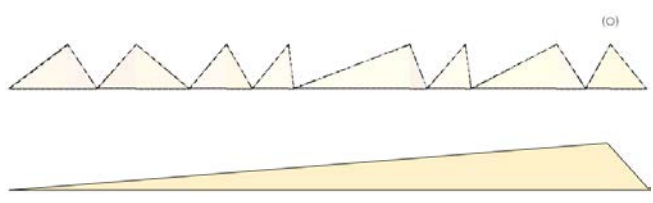

Signifier:	Primary semiosis	Secondary semiosis	Signified
Directional tendency (L <sub>3</sub> )	INFER+CONNOT	F <sub>0</sub>	Prayer to the Lord
Absence of harmonicity (L <sub>2</sub> )	CMPAR+INFER	F <sub>1</sub>	Separation, Unknowing, Waiting for the morning

[9" 45"]

[9" 45""

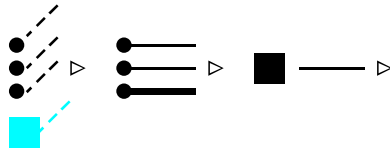

Signifier:	Primary semiosis	Secondary semiosis	Signified
Major chord + cluster (L <sub>1</sub> )	CMPAR+INFER +CONNOT	F <sub>2</sub>	Hope, Passion
Iterated variable sound (L <sub>1</sub> )	CMPAR+INFER	F <sub>1</sub>	More extrovert, Calling
Transformation from chord to cluster (L <sub>2</sub> )	CMPAR+INFER	F <sub>1</sub>	Discharged

[9"45"-10"49""

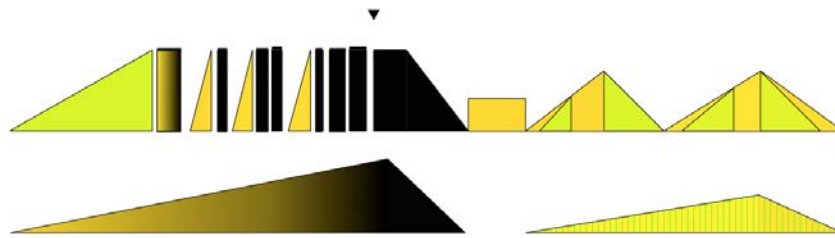

Signifier:	Primary semiosis	Secondary semiosis	Signified
Prominent consonance (L <sub>2</sub> ) + increasing tendencies (L <sub>3</sub> )	CONNOT	F <sub>2</sub>	Blessings
Gradually increasing clusters (L <sub>2</sub> ) + presence oriented tendencies (L <sub>3</sub> )	CONNOT	F <sub>1</sub>	Expelled sins
Static consonance (L <sub>2</sub> )	CMPAR+INFER	F <sub>2</sub>	Assurance, Fulfilment
Consecutive consonance and dissonance (L <sub>2</sub> )	CMPAR+CONNOT	F <sub>2</sub>	Brightness, Gratification

[10" 55"]



Signifier:	Primary semiosis	Secondary semiosis	Signified
Composite sound-object (L <sub>1</sub> ) + Dissonance with chord (L <sub>2</sub> )	CMPAR + CONNOT	F <sub>2</sub>	Bird song, Morning

[10"50""-11"30""]

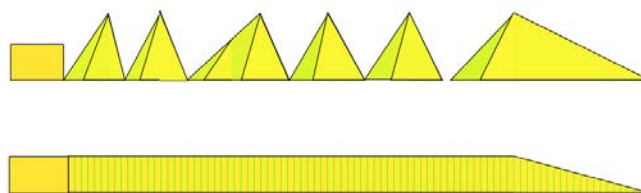

Signifier:	Primary semiosis	Secondary semiosis	Signified
Persistent harmonicity (L <sub>2</sub> )	CMPAR+INFER	F <sub>2</sub>	Unfailing love, Redemption,
Slight fusion of dissonance (L <sub>2</sub> )	CMPAR	F <sub>2</sub>	Brightness, Bliss

[11" 20"-11' 40"]

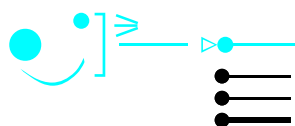

Signifier:	Primary semiosis	Secondary semiosis	Signified
Rit. + textural integration (L <sub>1</sub> )	CMPAR+INFER	F <sub>2</sub>	Resting, Becoming one with the Lord

#### 4.9 Conclusion regarding the semiotic interpretation

The work appears to form a kind of narrative line, where the play between harmonic colors and sound-characters conducts an essential outline for interpretation, since both elements operates as perceivable dichotomies. Signified indications are also highly determined by the interpretational performance. The segments of form-fields reveals three chapters of framework, where the endosemantics of the story suggest a conflict between states of iterated energy and complex textures, versus sustained energy and consonant harmonies. Proceeding one step further above the interpretation of endosemantic structures, one could reasonably interpret these exosemantic indications and impulses.

The next page depicts a collection of the most distinctive signified indications of the performance with sentence- and form-fields.

#### 4.10 De Profundis (Geir Draugsvoll): Signified indications and fields

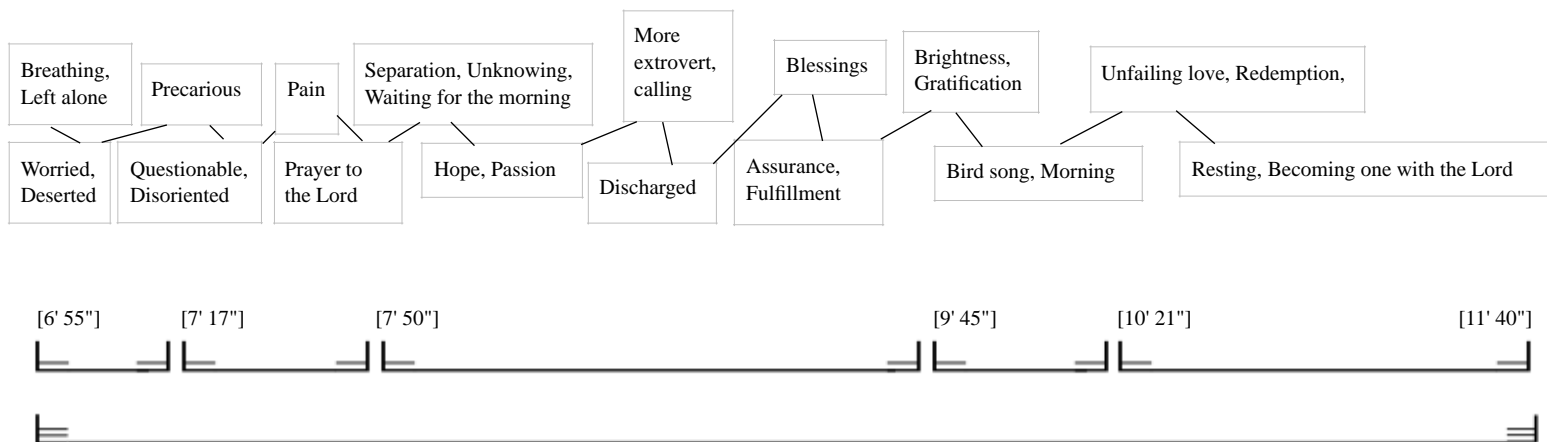
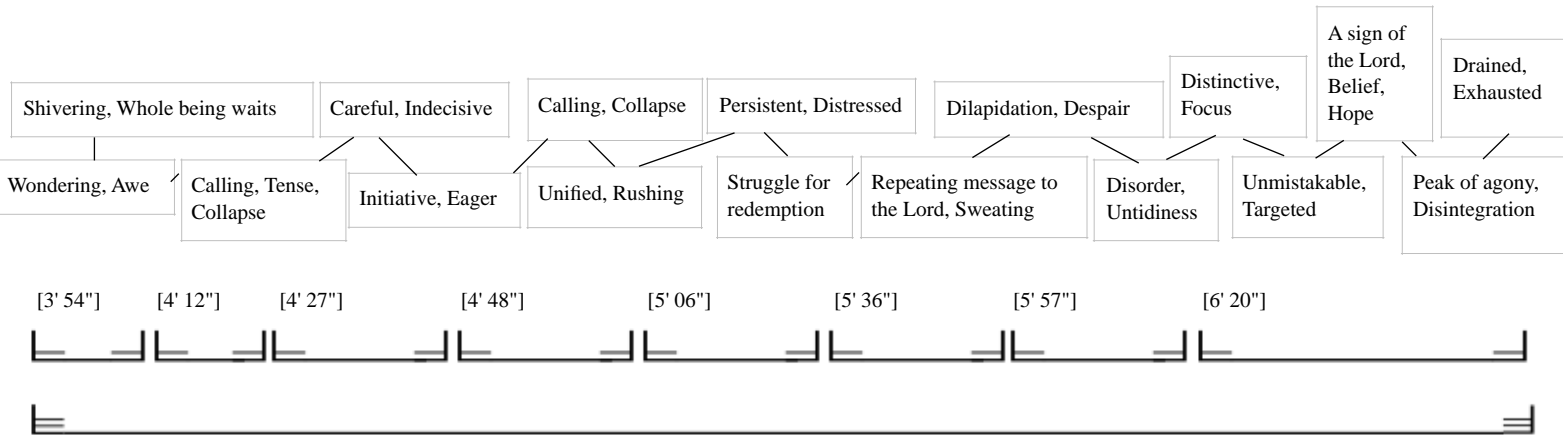
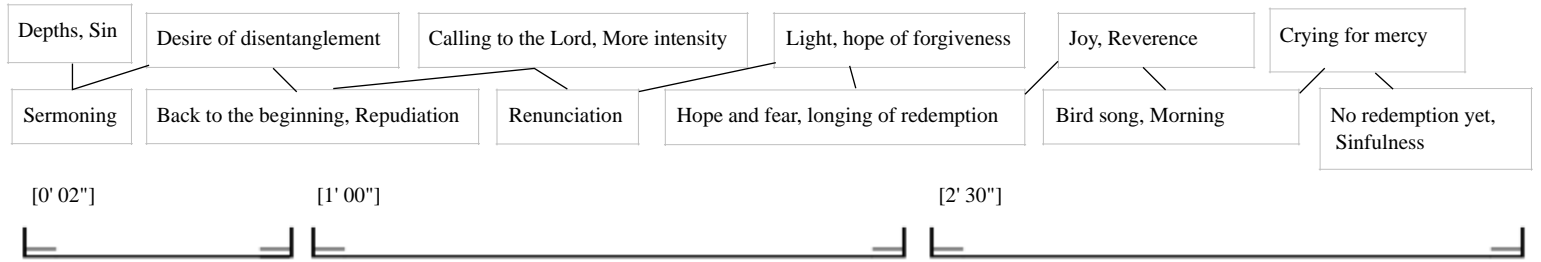

## 5 Method Part II

### 5.1 Terminology

These sections may provide information to the reader in order to comprehend the terminology of the signs that occurs in the aural analyses of *Sonate: Et Exspecto*. This chapter may serve as a continuance of the crash course in aural sonology intended in part one of the method chapter, including a proposal for new sign-concepts.

### 5.2 Melodic fragments - level two

An emerging musical dimension of melodic fragments may be perceived in parts of *Et Exspecto*. These perceived motions of sound-patterns are established from intervals in motion. They are not limited to specific pitches and durations, nor are they necessarily heard as recurring pitch-intervals. However, it is a criterion that a given degree in similarity of intervals are established, so the listener may recognize it as an established recurring fragment of motion. I wish to propose a creation of typology that may clarify these events.

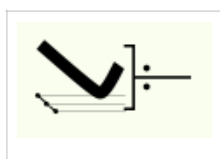

**Figure 5.1 - Fragment A**

Fragment A represents a *regular falling* pattern of intervals that ends with a rising interval (fig. 5.1). The sign could be applied to different intervals that fulfil the criteria of the illustration, which in this context is perceived as an *even direction* for the listener (preferably diatonic or chromatic scales). In *Et Exspecto*, this fragment is defined as a declining chromatic motion, followed by an increasing chromatic interval. A bulging chord is illustrated underneath, articulated through the typology of level one (spectromorphology). This sign indicates that each presented pitch of the declining chromatic motion is held sustained, thus creating a texture of the fragment.<sup>98</sup>



**Figure 5.2 - Fragment B**

The second sign represents an *oblique falling* pattern of intervals (fig. 5.2). Opposed to Fragment A, it is not perceived as an *even direction*; each note is repeatedly falling and rising. In *Et Exspecto*,

---

<sup>98</sup> The definition of a musical texture provides how the melodic, rhythmic and harmonic materials are combined.

this oblique falling motion can be identified both as a falling whole-tone interval and a rising chromatic-interval (*Et Exspecto*, 5th movement), or a larger falling interval (minor third, major third or fourth) and a rising chromatic-interval (*Et Exspecto*, 2nd movement). Thus, each falling note establishes a greater distance that is aurally perceived. This figure (5.2) does not involve a depiction of a level-one bulging chord, and is perceived singularly as a melodic fragment.

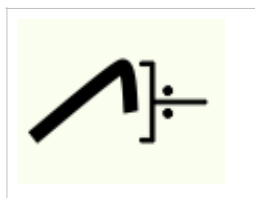

**Figure 5.3 - Fragment A inverted**

The third sign represents an inversion of fragment A (fig. 5.3). In the analysis of *Et Exspecto*, it represents an *even rising* pattern of close intervals that end with a *falling* close interval.

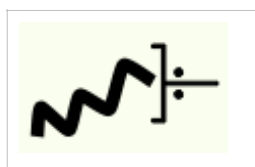

**Figure 5.4 - Fragment B inverted**

The fourth sign represents an inversion of fragment B: an *oblique rising* pattern of intervals (fig. 5.4). In the analysis of *Et Exspecto*, it represents a larger, rising interval, followed by a shorter, falling interval.

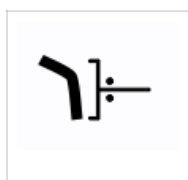

**Figure 5.5 - Fragment C**

The fifth sign represents a falling pattern of two intervals (fig. 5.5). In *Et Exspecto*, this motion is manifested as a chromatic interval (even motion), followed by a major third-interval which is perceived as a higher leap.<sup>99</sup>

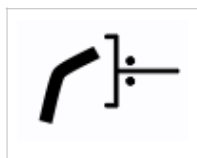

**Figure 5.6 - Fragment C inverted**

The sixth sign represents an inversion of fragment C (fig. 5.6): A rising pattern of two intervals, a major-third motion followed by a chromatic motion (*Et Exspecto*).

---

<sup>99</sup> A familiar reference to this melodic fragment could be the identical melodic leitmotif that often characterize the works by Edvard Grieg.



**Figure 5.7 - Fragment D and inversion**

The seventh sign represents a rising chromatic pattern of chromatic intervals (fig. 5.7), while the eighth represents an inversion; a descending pattern of chromatic intervals (*Et Exspecto*).

### 5.3 Flux - level two

Thoresen situates flux as an endosemantic category, or the contextual meaning, arising between opposites of flow and friction.<sup>100</sup> This contextual meaning deals with the impression of smoother flow or more friction in different musical dimensions of time structures. The examples provided in *Emergent Musical Forms* are:

- transition from slower to faster rhythmical values
- from irregular to regular movement
- from staccato/marcato character to legato character<sup>101</sup>

The following signs are used for aural analysis of flux:

1) For use on the levels of object-fields and phrase fields:

stop	more friction		less friction	flow
	<<<	<< <	> >>	>>>

**Figure 5.8 - Flux (object-fields and phrase-fields)<sup>102</sup>**

2) For describing the general character of a sentence-field or a form-field:

stop	more friction		less friction	flow
	⇐	⇐	⇒	⇒

**Figure 5.9 - Flux (character of sentence-field or form-field)<sup>103</sup>**

<sup>100</sup> Thoresen, *Emergent musical forms*, 347.

<sup>101</sup> Ibid.

<sup>102</sup> Ibid.

<sup>103</sup> Ibid, 348.





The signs may be interpreted as arrows pointing backwards (left), indicating friction, and arrows pointing forwards (right), indicating flow.

Since the context of analysis in this part will focus on different examples of interpretations and less on collectively larger forms, the analysis is limited to phrase-field considerations. In spite of the analyses' lack of larger fields, the interpretation of general flux-character will in some examples be provided. Also, the work *Et Exspecto* deals with great separation of phrases through silence, as well as the oppositional large conjunctions of phrases. Therefore, a hermeneutic decision is made to approach the consideration of fields as it is interpreted in the isolated examples. A flux character description (fig. 5.9) will therefore be placed underneath the phrase-fields, while the first flux-signs will be placed over the phrase-fields (fig. 5.8).

#### 5.4 Enfold versus unfold - level two

As a distinction from the previous method of considering time structures of music (flux), this contextual meaning is more intently related to harmonic, melodic and timbral dimensions.<sup>104</sup> The help of other characteristics by Thoresen describes the general focus in this category, as the terms enfold/unfold is not immediately obvious for the reader:

	enfolded	unfolded	
	enclosed	open	
	sombre	bright	
	clustered	expanded	
	constrained	released	
Notation:			

**Figure 5.10 - Enfold versus unfold<sup>105</sup>**

The arrow between the symbols suggests a transition or a movement towards change.

Thoresen situates several different musical dimensions that could be perceived as the enfold-unfold effect:

- a minor tonality is more enfolded than a major tonality
- small melodic intervals are more enfolded than a higher ones
- a nasal instrumental timbre is more enfolded than a bright one
- voices moving in opposite directions towards each other are more enfolded than voices moving in opposite directions away from each other

<sup>104</sup> Ibid.

<sup>105</sup> Ibid.

- mediant-oriented harmony more unfolded than normal fifth and fourth relations within a single tonal plan<sup>106</sup>

The author articulates the importance of interpretation in context and the characteristics should not be taken dogmatically, indicating that the list of specific dimensions is not completed. The music of Gubaidulina includes a broad harmonic spectrum, ranging from clear consonant harmonies to more dissonant-colored chords, which will require new characteristics of interpretation in regard to the effect of enfold-unfold. A perception of a dissonant major harmony (that still is perceived as a major harmony) will be considered as brighter and unfolded in opposition to a consonant minor harmony.

### 5.5 Concord versus discord - level two

This third and last applied method of contextual meaning concerns interpretations of conflicts occurring in single musical dimensions, such as dissonant intervals or disturbances of metrical functions.<sup>107</sup> This sign can be highly relevant in the combination of enfold-unfold interpretation, as it may articulate the difference between, for example, an enfolded-concord harmony and an unfolded-discord harmony.

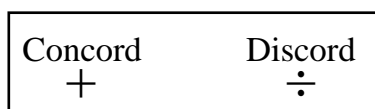

**Figure 5.11 - Concord versus discord<sup>108</sup>**

---

<sup>106</sup> Ibid, 348.

<sup>107</sup> Ibid, 349.

<sup>108</sup> Ibid.

## 5.6 Form-building processes and form-building transformations - level three

### 5.6.1 Form-building processes

Form-building processes is the description of play with patterns of similarity and contrast. Traditional analysis of musical forms in Western classical music, has had a prevailing approach towards «thematic form». The method of sonology prefers the term «form-building processes», since other genres, such as contemporary music or sound-based music, may not use themes in the traditional manner. Still, it may be fruitful to describe relationships based on similarity and contrast.<sup>109</sup>

Thoresen situates the traditional approaches on three relationships fundamental to form-building processes: recurrence, variation and contrast. A representation may be established as AA, AA' and AB, suggesting relationships spanning from greater similarity to greater difference. He further presents six degrees of similarity/dissimilarity which intend to clarify relationships with more sufficient accuracy of form-building processes, especially in contemporary or sound-based music.

Concepts	Definitions	Signs	Expressions	Traditional concepts
Recurrence	Exact similarity An element is repeated exactly.	=	$a = a$	AA (Recurrence)
Slightly varied recurrence	Greater similarity An element is slightly varied and easily recognised.	$\approx$	$a \approx a$	AA or AA' (Recurrence or variation)
Strongly varied recurrence	Remote similarity An element is much varied and not so easy to recognize as the same.	$\approx$	$a \approx a'$	AA' (Variation)
Related contrast / medium contrast	Very remote similarity The element is perceived as a contrast, yet as related.	$\neq$	$a \neq a'$ $a \neq b$	AB (Contrast)
Great contrast	Dissimilarity The element is perceived as very different, without any evident relationship.	$\neq$	$a \neq b$	AB (contrast)
Unrelated contrast	Strong dissimilarity The element is perceived as entirely unrelated.	$\neq$	$a \neq b$	?

<sup>109</sup> Ibid, 447.

## Figure 5.12 Degrees of similarity / dissimilarity<sup>110</sup>

### 5.6.2 Typology of form-building elements

Musical form is perceived through the aural experience of relations between certain constituent elements. Form-building elements are a descriptive tool in aural sonology that serves to characterize the complexity of elements.

These elements are often established through melodic and rhythmical lines that are perceived in the foreground layer(s).<sup>111</sup> A definition of different layers in music shall be presented before continuing the topic of form-building elements.

The ear is capable of perceiving several simultaneous layers of sounds and these layers may have different functions.<sup>112</sup> A foreground or background layer is a description of a musical orientation of what the listener singles out as foreground or background, much like a viewer would regard in visual fields. Thoresen situates examples in chapter seven (*layers and their functions*) where he claims that the listener will prefer medium short sounds as foreground when they occur simultaneously with long sounds. An intensive sound profile, vivid motion or significant changes would easily be singled out as foreground opposed to others that don't. Form-building significance may be obtained by musical textures, such as a chord or cluster. There is also a gradual transition between line and texture, such as lines being superposed to appear like a texture.<sup>113</sup>

Therefore, the discourse of complexity of form-elements is applied both to lines (melodic and rhythmic elements) and to textures.<sup>114</sup> The next models depicts how the typology of form-building elements is based on their complexity (fig. 5.13 and 5.14).

---

<sup>110</sup> Ibid, 448.

<sup>111</sup> Ibid, 453.

<sup>112</sup> Ibid, 379.

<sup>113</sup> The term *superposed* is defined by placing something on or above something else, so that they coincide. However, the term *superimposed* is defined by placing one thing over another, typically so that both are still evident. First, the term *superposed* should suggest less conspicuous parts that acts simultaneously, so it may be perceived as a combined texture. Second, the term *superimposed* should suggest a conflict between the simultaneous parts, causing them to be observed as separate parts and thus creates an entirety that is more external and alien.

<sup>114</sup> Ibid, 454.

MELODIC ELEMENTS, LINES			TEXTURES			
Complexity	Integral	Partitioned		Integral	Partitioned	
Very complex						
Relatively complex						
Moderately complex						
Relatively simple						
Very simple						

**Figure 5.13 Typology of form-building elements<sup>115</sup>**

The following examples of lines and textural definitions are stated by the author and may serve useful in order to interpret how a listener may categorize the complexity of form-building elements (fig. 5.14).

Complexity	Lines (examples)	Textures (examples)
Very simple elements	Repetitive figures with one or a couple of pitches and even rhythmical values such as very simple accompaniment figures.	Single chords, monophony or basic homophony.
Relatively simple elements	Articulated yet simple figures such as scales/passages or refined accompaniment figures.	Heterophony, or homophony with slight polyphonic elements.
Moderately complex elements	A classical, simple theme.	A simple two-or three-part polyphony.
Relatively complex elements	Complex themes with great diversity of pitch and rhythm.	Complex polyphony.
Very complex elements	Extremely asymmetric/irregular lines using a large number of values in an unpredictable manner.	Accumulations in electroacoustic and avant-garde music.

**Figure 5.14 Definitions and examples<sup>116</sup>**

<sup>115</sup> Ibid, 455.

<sup>116</sup> Ibid, 454.

### 5.6.3 Defining textures

The next model shows the different musical textures, used as examples in the previous figure (5.6).

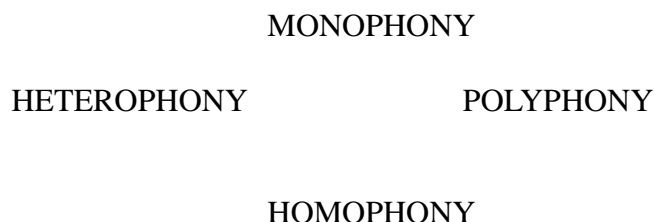

*Monophony* is the simplest of musical textures. It consists often of a melodic pattern played or sung by a single instrument or voice. Still, the term homophony is associated with the concord and alignment between voices in the texture, compared to the term monody that speaks of a solely soloistic role of the melody. The term monophony may therefore serve as both a single melodic line either performed collectively (octaves) or unison.

*Homophony* is a texture where multiple parts (of different pitch) generally move in the same rhythm and is also referred to as *chordal* music.

*Heterophony* represents multiple parts that use the same melodic material, but somewhat at different times. In this context, any vertical alignment of intervals is coincidental and not important.

*Polyphony* means music with more than one part, where rhythmic distinction and independence are the criteria for each part.<sup>117</sup>

The scale of complexity may to some degree be considered relative to the composition that is being analyzed.<sup>118</sup> This is an essential reminder for a listener approaching form-building elements with hermeneutic intensions. A form-element, such as a classical theme, will often be presented in its *integral* form, and then be broken down by being *partitioned* into smaller motives. One example of this is the opening of the famous march from Prokofiev's opera *The Love For Three Oranges*:

---

<sup>117</sup> Todd M. McComb, "What is monophony, polyphony, homophony, monody etc.?", Medieval Music & Arts Foundation, <http://www.medieval.org/emfaq/misc/homophony.html> (28.03.17).

<sup>118</sup> Thoresen, *Emergent Musical Forms*, 454.

MOTIVE A      MOTIVE B      PARTITIONING

THEME

**Figure 5.15 Sergej Prokofiev, *March* - Illustration of form-building elements<sup>119</sup>**

When a theme is partitioned, a form-building transformation may be observed. Thoresen presents many different processes that may occur, such as *simplification*, *complication*, *integration*, *fragmentation* et cetera. Any form-building transformation that occurs in the analyses of Gubaidulina, will be reflected and explained. The reader is suggested to read more about form-building transformations in chapter nine of *Emergent Musical Forms* or read a summary at the website for further study.<sup>120</sup>

A form-segment may also appear *distinctive*, meaning that it sets it apart from other segments in context. The analytic tool used to define a form-segment distinctive, is to consider the articulation of the object. If it is strongly articulated, then the sign is marked with a horizontal line.

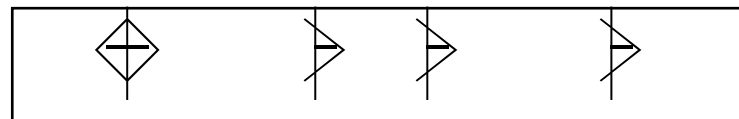

**Figure 5.16 Articulated form segments of Prokofiev's example**

The example of Prokofiev's march is more precisely illustrated with a distinctive interpretation of the opening segment. If a different character of form-element appears unarticulated, it shall be considered anonymously and will not be assigned a horizontal line.

<sup>119</sup> The example illustrates a harmonic reduction of the orchestral score, originally arranged by Bjarke Mogensen for solo accordion, bar 3-6.

<sup>120</sup> [www.auralsonology.com](http://www.auralsonology.com).

## 6 Et Exspecto

With the following chapter, I intend to provide knowledge concerning multiple interpretations of the selected work. Unlike the extensive analysis of *De Profundis*, the aim of this study is to compare shorter examples in order to illuminate different choices made by the performers and how these choices are perceived through sonic and structural elements. This leads to the question of how different interpretations may represent different metaphors. The material may hence be interpreted exosemantically in search for a spiritual meaning. The analyses and exosemiotic interpretations will be presented with selections from each movement (I-V) and include chosen recordings of the following performers: Friedrich Lips (1992), Geir Draugsvoll (1995), Iñaki Alberdi (2011) and myself, Andreas Angell (2015).<sup>121</sup>

A presentation of both Friedrich Lips and Geir Draugsvoll has been previously established, thus a short introduction of the performer Iñaki Alberdi is provided in the next text.

### 6.1 Iñaki Alberdi

The Spanish accordionist completed his education under Friedrich Lips and Matti Rantanen at the International Centre for Accordion Studies, the Gnessin Institute in Moscow, and the Sibelius Academy in Helsinki. Alberdi has collaborated closely with different current composers, and premiered works by Sofia Gubaidulina, Karlheinz Stockhausen, Luis de Pablo, Jesús Torres and many other leading contemporary composers from Spain. He has currently published six recordings and was nominated for the Gramophon Editor's Choice Award for his monographic record on Sofia Gubaidulina.<sup>122</sup>

I have chosen to not conclude thorough analyses of every performer's action in each movement, but preferred to compare two interpretations with each other. The selection of interpretive examples are:

1st movement, opening: Alberdi versus Angell, 1st movement, ending: Draugsvoll versus Lips.

2nd movement, opening: Angell versus Alberdi, 3rd movement, opening: Draugsvoll versus Lips.

4th movement, opening: Angell versus Lips. 4th movement, ending: Draugsvoll versus Lips,

5th movement, whole: Alberdi versus Lips.

My choices are not necessarily systematic, but they are selected interpretations I find

---

<sup>121</sup> Sofia Gubaidulina, Friedrich Lips, *ET EXSPECTO*, 1992, Classical Accordion CD.

Sofia Gubaidulina, Iñaki Alberdi, *Gubaidulina: Kadenza*, 2011, EtCetera-Records.

<sup>122</sup> Biography, MUSIESPAÑA, <http://www.ialberdi.com/en/biography/> (30/04/17).



interesting to compare, as they could be very different. I will advise the reader to listen to the assigned video link, as the text clarifies emerging musical forms which is heard and not easily seen in the text itself (<http://bit.ly/2prw7y4>).

## 6.2 The title

The title *Sonate: Et Exspecto* refers to the second last line 'Et exspecto resurrectionem mortuorum' (I look for the resurrection of the dead), in the Nicene Creed. In the Orthodox Church the creed is usually called The Symbol of Faith and is widely used in Christian liturgy. In English, the sentence is often translated as 'I look for the resurrection of the dead, and the life of the age to come' (... , Et vitam venturi saeculi). The word creed originates from the Latin *credo* meaning "I believe", and the meaning of The Symbol of Faith is 'bringing together', 'expression' or 'confession' of the faith.<sup>123</sup> The different endosemantic indications of *Et Exspecto* could be interpreted exosemantically in context to this reference of the Nicene Creed.<sup>124</sup>

However, the exosemantic interpretation will be limited to the general character of each performance and common semantic elements that occur in both performances. As the analysis concerns parts of the sonata and not the whole, exosemantic references to the Nicene creed will serve as an inspiration, though less emphasized as a structure of meaning.

I believe in one God, Father Almighty, Creator of  
heaven and earth, and of all things visible and invisible.

And in one Lord Jesus Christ, the only-begotten Son of  
God, begotten of the Father before all ages;

Light of Light, true God of true God, begotten,  
Not created, of one essence with the Father  
Through Whom all things were made.

Who for us men and for our salvation  
Came down from heaven and was incarnate  
Of the Holy Spirit and the Virgin Mary and became man.

He was crucified for us under Pontius Pilate,  
And suffered and was buried;  
And He rose on the third day, according to the Scriptures.

He ascended into heaven  
And is seated at the right hand of the Father;

And He will come again with glory to judge the living  
And dead. His kingdom shall have no end.

And in the Holy Spirit, the Lord, the Creator of life,  
Who proceeds from the Father, Who together with the  
Father and the Son is worshipped and glorified, Who  
spoke through the prophets.

In one, holy, catholic, and apostolic Church.

I confess one baptism for the forgiveness of sins.

I look for the resurrection of the dead,  
and the life of the age to come.

Amen.

<sup>123</sup> "The Nicene Creed", *Orthodox Church in America*, <https://oca.org/orthodoxy/the-orthodox-faith/doctrine-scripture/the-symbol-of-faith/nicene-creed> (30/4/17).

<sup>124</sup> "The Nicene Creed", *Greek Orthodox Archdiocese of America*, <https://www.goarch.org/-/the-nicene-creed> (30/4/17).

### 6.3.1 Aural Analyses: 1st movement - opening

Performers: Iñaki Alberdi/Andreas Angell

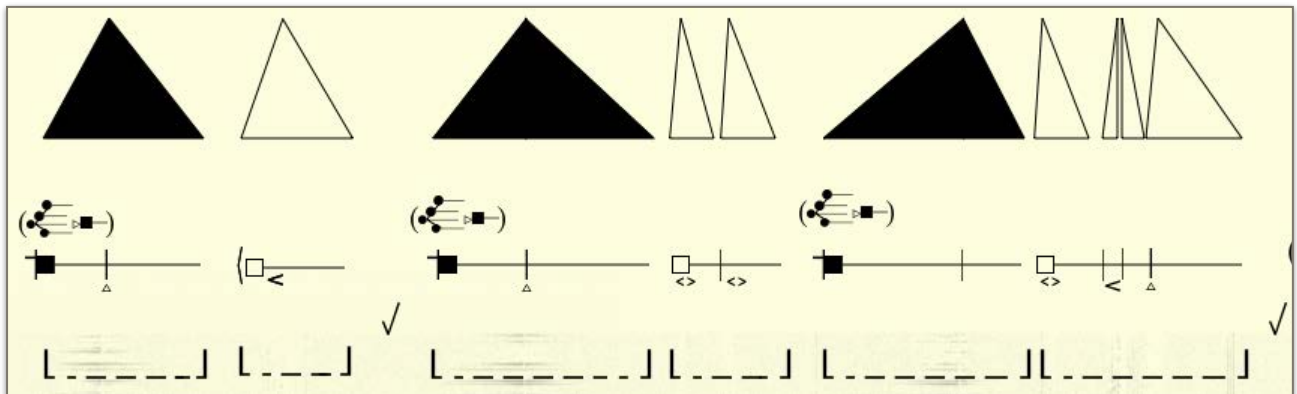

**Figure 6.1 - Alberdi 0'01''-0'47'', 2nd video, <http://bit.ly/2prw7y4><sup>125</sup>**

The figure (6.1) displays a certain play between reappearing clusters and air-sounds in expansion. These elements are perceived as separate object-fields (object-field focus), as the air-sounds are perceived with distinct articulation (illustrated with the sign gradual onset/swelled onset on unvoiced sound-object). Distinct articulation is further perceived on the different brusque onsets indicated in the analysis. The appearing character of the cluster is performed as bulging pitches transforming into a texture ( $L_1$ ). The sign for spectral brightness is interpreted in this context to illustrate register, and this specific example depicts a bright register for the texture ( $L_1$ ). The vertical lines across the prolongation line indicate the marked reappearance of the sound-object.

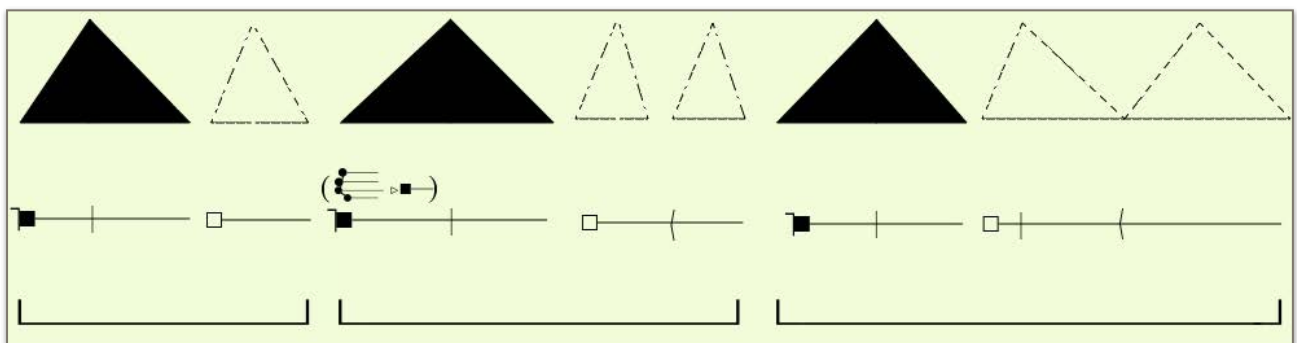

**Figure 6.2 - Angell 0'01''-0'56'', 3rd video, <http://bit.ly/2prw7y4><sup>126</sup>**

<sup>125</sup> Sofia Gubaidulina, *Sonate Et Exspecto*, Musikverlag Ulrich Schmülling (Deutschland), score, page 1, bar 1-5.

Page 1 refers to first page of notated score.

<sup>126</sup> Ibid.

In this figure (6.2), the play between cluster and air-sound are perceived as a combined phrase-field (phrase-field focus); it may be heard as an aligned reflection of silence that the texture leaves behind, as regards to its indistinctive character (illustrated as a *faint tendency*). Thus, the relations between these sound-objects create a durable continuum. The cluster is heard in a brighter register than the previous example, indicated by the sign for spectral brightness. The soft articulation, passive appearance of sound-characters, less dynamic energy and joint tendencies are different dimensions that create a reticent character compared to Alberdi (figure 6.1).

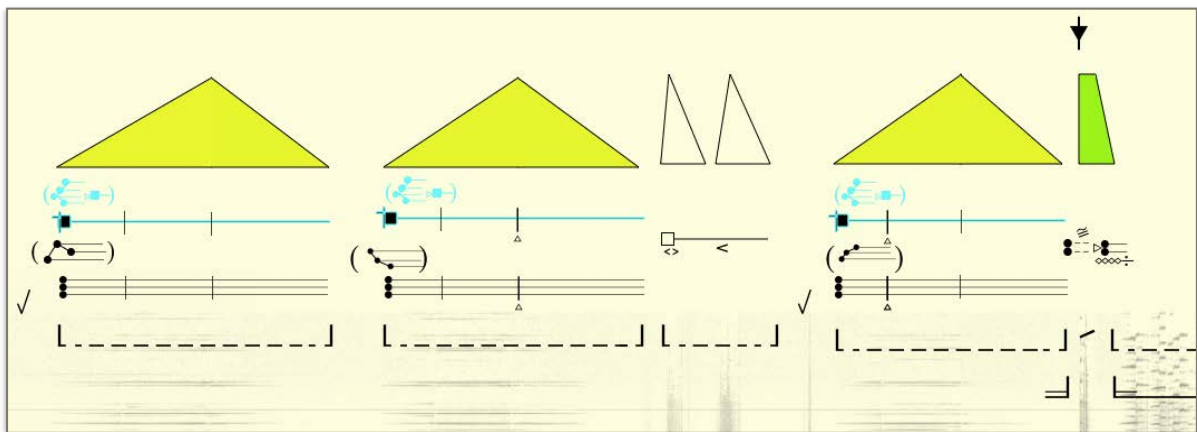

**Figure 6.3 - Alberdi 0'48''-1'44'', 2nd video<sup>127</sup>**

The appearing character of the minor chord (fig. 6.3) is performed with a similar bulging character established by the previous complex textures (fig. 6.1). A chorale is presented and the light-green/slight-yellow color indicates a prominent consonance of the harmonic fusion of dichotomy (fig 6.3). Air-sounds are articulated and perceived as a separate object-field. A separation point is perceived as a transition, with the sudden separation of the specific time-field. In this place, a new sound-object occurs; the tritone interval.

This short appearance is heard with two energy articulations:

first) iterated, oblique flutter-time ▷ second) sustained, small-fast dynamic gait

The vertical lines across the prolongation indicate the marked reappearance of the cluster, and the chords' change in pitch. The first articulation is identified as the 'quadruple bellow-shake', a known

<sup>127</sup> Ibid, page 1, number 1, bar 6-15.

term for many classical accordion performers, which was introduced by Lips in his first interpretation of this piece.<sup>128</sup>

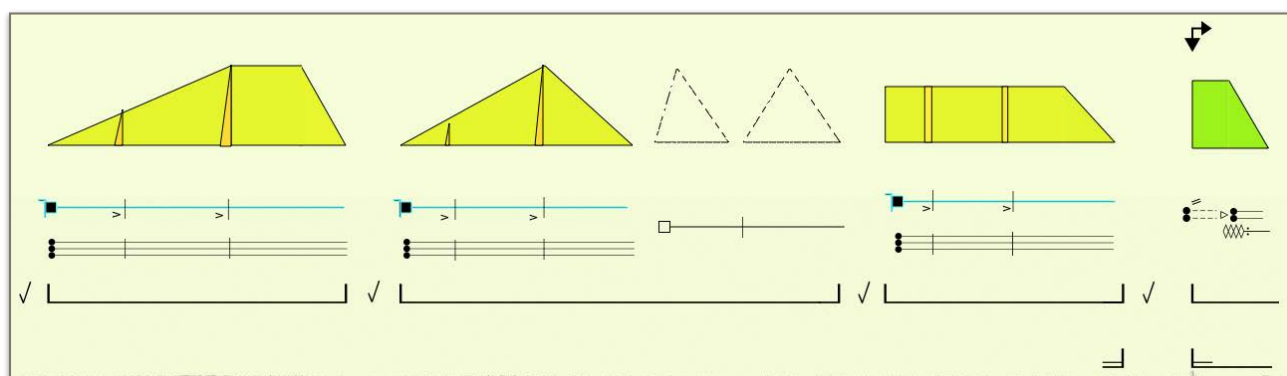

**Figure 6.4 - Angell 0'57''-2' 07'', 3rd video<sup>129</sup>**

The minor chord is played with a similar character as the established cluster, not as a bulging texture, but the cluster is briefly rounded off before the next onset of chords. As a result, small spaces of clear consonance can be seen as yellowness in the light-green harmonic fusion (fig 6.4). The air-sounds are interpreted in the analysis as an extension of the phrase-field, because of its subtlety of emblematical silence or reflection that connects with the chorale. The third phrase-field in the example is perceived as a static-decreasing tendency, in contrast to other phrase-fields. After a noticeable silence, a sudden articulation of the tritone interval occurs and functions as a release point to the listener. The tritone contains a rather different energy articulation compared to Alberdi's performance (fig.6.3):

first) regular ripple-time   ▷   second) large-fast dynamic gait

The first articulation is performed with a different technique (combination of regular bellow shake and ricochet<sup>130</sup>) than the 'quadruple shake', creating a different energy character to the sound-object.

<sup>128</sup> The quadruple-shake emerged from an intension from the composer, as she was searching for a different iterated sound from the instrument, opposed to the regular bellow-shake. A proposition was established by Lips, giving a new irregular sound-quality which was generated in five orders by the use of bellow; 1) Top out, 2) Bottom out, top inn, 3) Top and bottom out, 4) Top inn, 5) Top out.

Friedrich Lips, *The Art of Bayan Playing*, (Karthause Schmülling Publications, 1991), 73.

<sup>129</sup> Gubaidulina, *Sonate Et Exspecto*, page 1, number 1, bar 6-15.

<sup>130</sup> Bellow-Ricochet is heard as a rhythmic value of triplets, which is achieved by using the following steps with the bellow: 1) Top out, 2) Top inn, bottom out, 3) Bottom inn.

Lips, *The Art of Bayan Playing*, 71.

Three large separations of silences is noticeable in Alberdi's performance, one after the elements of cluster and air-sound is presented (fig 6.1), one before the start of the chorale (fig 6.3) and one before the last choral line. However, four large separations of silences are perceived in Angell's interpretation before and after each chorale-line (fig 6.4). These silences do not occur in the same place of both interpretations, except for the silence before the last choral line.

### 6.3.2 Exosemantic Interpretation - 1st movement - Alberdi versus Angell

The chart depicts some common semantic elements first, possibly intrinsic to the composition itself. Furthermore, the general character of each interpretation is treated as semantic indications that are interpreted exosemantically.

<b>Common semantic elements</b>				
<b>Signifier</b>	<b>Semiosis</b>	<b>Signified-&gt;Signifier</b>	<b>Semiosis</b>	<b>Signified</b>
Bright clusters (L <sub>1</sub> )	CMPAR (F <sub>2</sub> )	Lights	CONNOT (F <sub>2</sub> )	Looking up
Air sounds (L <sub>1</sub> )	CMPAR (F <sub>1</sub> )	Breathing	CONNOT (F <sub>1</sub> )	Breeze
Consonant chorale with clusters (L <sub>2</sub> )	INFER (F <sub>0</sub> )	Mankind and light	CONNOT (F <sub>2</sub> )	Spiritual belief
<b>Iñaki Alberdi</b>				
Darker sonorities, distinct articulation and object-field focus (L <sub>1</sub> )+ (L <sub>2</sub> )+ (L <sub>3</sub> )	CMPAR +INFER (F <sub>1</sub> )	Extrovert	CONNOT (F <sub>2</sub> )	Earthly, Confident
<b>Andreas Angell</b>				
Brighter sonorities, indistinct articulation and phrase-field focus (L <sub>1</sub> )+ (L <sub>2</sub> )+ (L <sub>3</sub> )	CMPAR +INFER (F <sub>1</sub> )	Introvert	CONNOT (F <sub>2</sub> )	Ethereal, Humble

### 6.4.1 Aural Analyses: 1st movement - ending

Performers: Geir Draugsvoll/Friedrich Lips

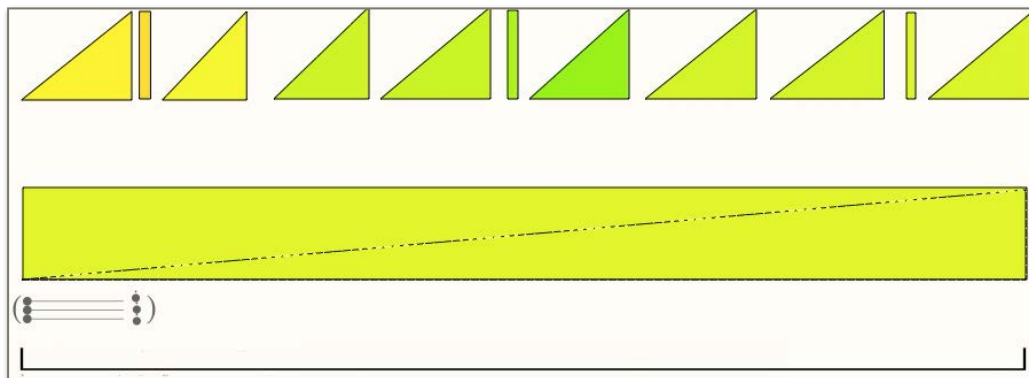
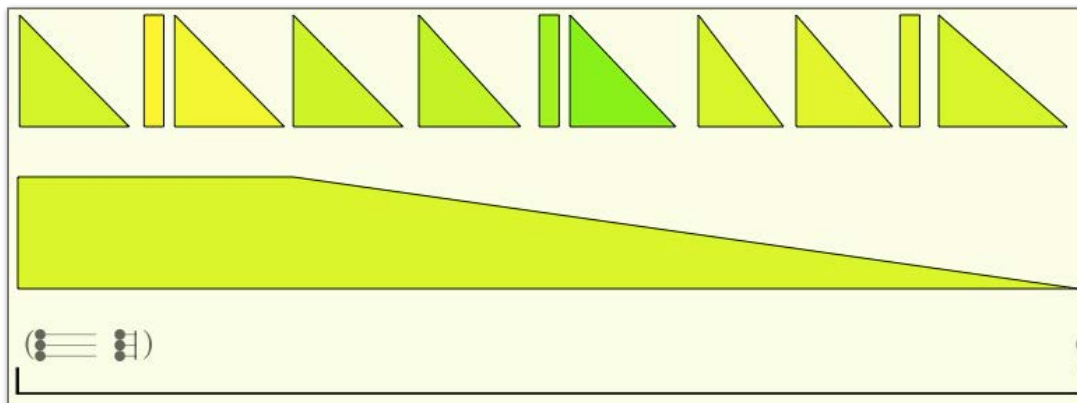

**Figure 6.5 - Draugsvoll 2'01''-2' 27'', 4th video, <http://bit.ly/2prw7y4><sup>131</sup>**

A distinct progression of chords emerges towards the ending of the first movement (fig 6.5). The analysis depicts increasing tendencies of sustained chords, with three exceptions of chord impulses. The colors indicate the following harmonic process:

clear consonant → slight dissonances → stronger dissonances → slight dissonances

A faint directional tendency is indicated in the lower dynamic model.



**Figure 6.6 - Lips 2'01''-2' 27'', 5th video, <http://bit.ly/2prw7y4><sup>132</sup>**

The analysis depicts a somehow reversed-interpretation in comparison to Draugsvoll's performance (fig 6.5); decreasing tendencies of sustained chords, and three sustained chords with a marked ending (fig.6.6).

<sup>131</sup> Gubaidulina, *Sonate Et Exspecto*, page 2, number 3, bar 7-14 (ending before number 4).

Bar 7 represents the seventh bar of that page, not of the movement as a whole.

<sup>132</sup> Ibid.

The colors indicate a similar harmonic process, with an interesting exception of the first harmony; instead of a perfect minor chord (as heard in the example by Draugsvoll), it contains a high major seventh.



Figure 6.7 - Score excerpt

The score itself depicts the major seventh (fig. 6.7), but that does not necessarily mean it should be played. It could be a misprint or directly be regarded as a different harmonic interpretation rather than a mistake, which could be tracked to other similar musical-elements in the piece, such as the opening of the fourth movement:



Figure 6.8 - Score excerpt

As this movement opens with a perfectly consonant minor chord (fig 6.8), the previous motion could be an interpretive choice to designate a stronger similarity to the opening of both parts.

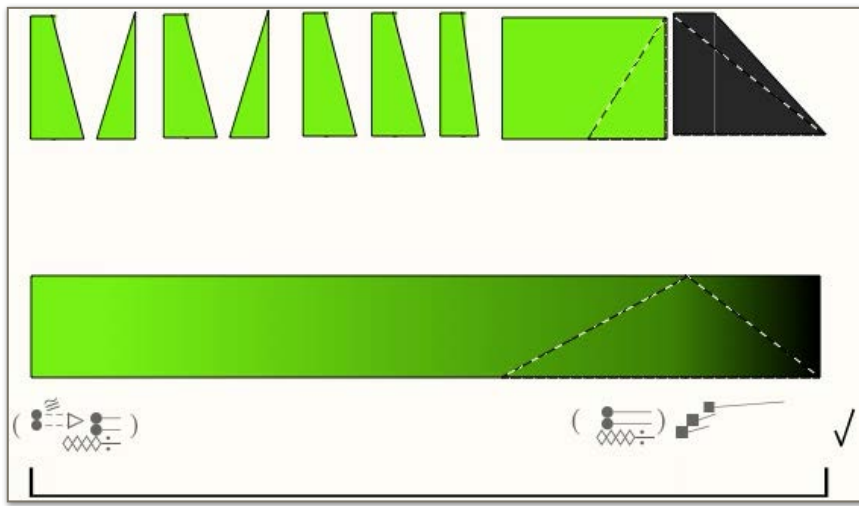

**Figure 6.9 - Draugsvoll 2'27''-2' 43'', 4th video<sup>133</sup>**

The last part of this example contains partly of the similar tritone-element heard in the end of the opening movement. The analysis depicts the sound-objects as an articulated transformation from iterated oblique flutter-time, to sustained middle-fast dynamic gait. The last event is three ascending clusters, where the third has the longest duration and results in silence.

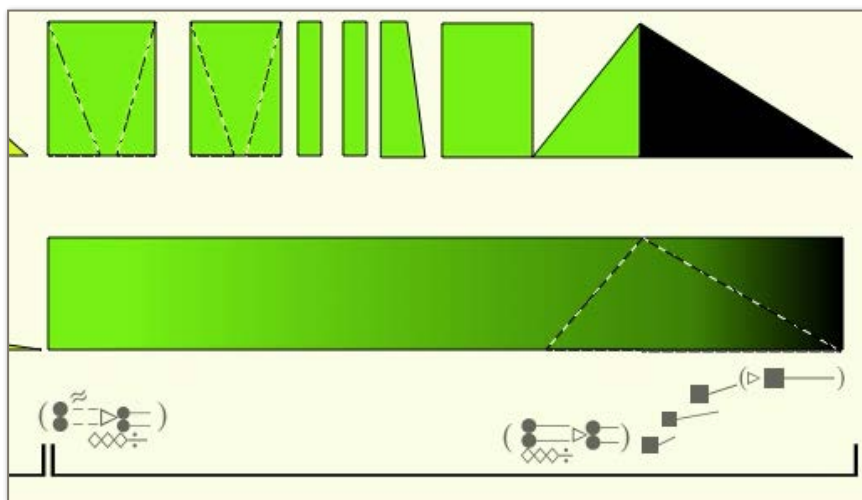

**Figure 6.10 - Lips 2'45''-3' 05'', 5th video<sup>134</sup>**

The pulse categories are perceived differently; fig. 6.9 (Draugsvoll) depicts faster iterations and gait, while the figure 6.10 (Lips) is perceived slower and more irregular. The duration of time between the illustrated analyses (fig 6.9+fig.6.10) and the previous parts (fig 6.5+fig 6.6) is slightly longer in the performance of Draugsvoll, while Lips' performance begins with a faster attack. Tendencies are also more connected (fig. 6.10) compared to Draugsvoll (fig 6.9), but in the end, Lips chooses to separate the dynamic gait of the stable-sustained pitch. The third variable cluster

<sup>133</sup> Ibid, page 2, number 4, bar 15-23 (end).

<sup>134</sup> Ibid.



ends with a fermata (fig 6.10), oppose to the first example that results more quickly into silence (fig. 6.9).

### 6.6.2 Exosemantic Interpretation - 1st movement - Draugsvoll versus Lips

<b>Common semantic elements</b>				
<b>Signifier</b>	<b>Semiosis</b>	<b>Signified-&gt;Signifier</b>	<b>Semiosis</b>	<b>Signified</b>
Dissonant chorale/Chord progression (L <sub>2</sub> )	CMPAR (F <sub>2</sub> )	Destruction of something sacred	CONNOT (F <sub>2</sub> )	Passion of Jesus Christ's Crucifixion
Iterated tritone (L <sub>1</sub> )	CONNOT (F <sub>0</sub> )	Evil		
<b>Geir Draugsvoll</b>				
Increasing tendencies, short chord-impulses and closing variable cluster (L <sub>1</sub> )+(L <sub>3</sub> )	CMPAR +INFER (F <sub>1</sub> )	Determined	CONNOT (F <sub>0</sub> )	Inevitable force
<b>Friedrich Lips</b>				
Decreasing tendencies, marked chord-gestures and closing sustained cluster (L <sub>1</sub> )+(L <sub>3</sub> )	CMPAR +INFER (F <sub>1</sub> )	Reserved	CONNOT (F <sub>2</sub> )	Painful

### 6.5.1 Aural analyses: 2nd movement - opening

Performers: Andreas Angell/ Iñaki Alberdi

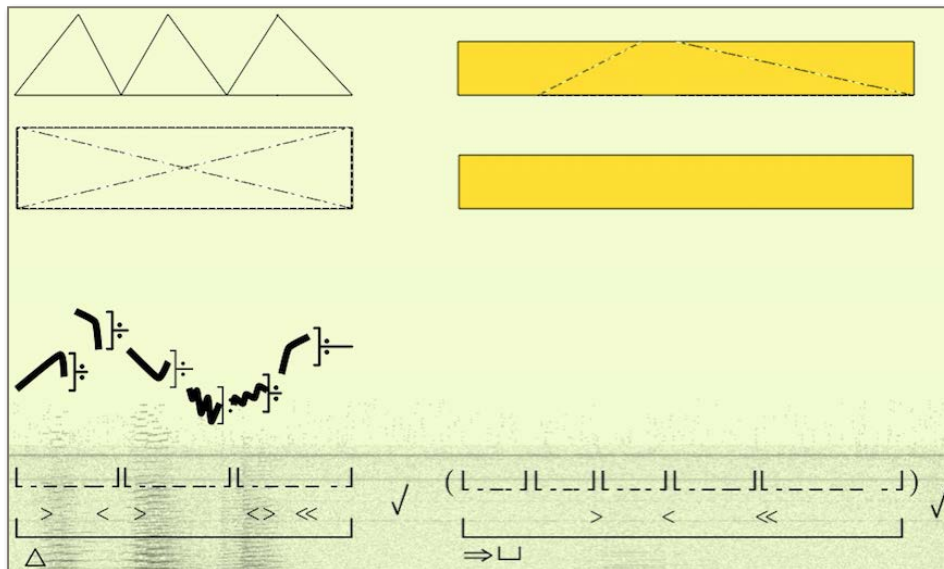
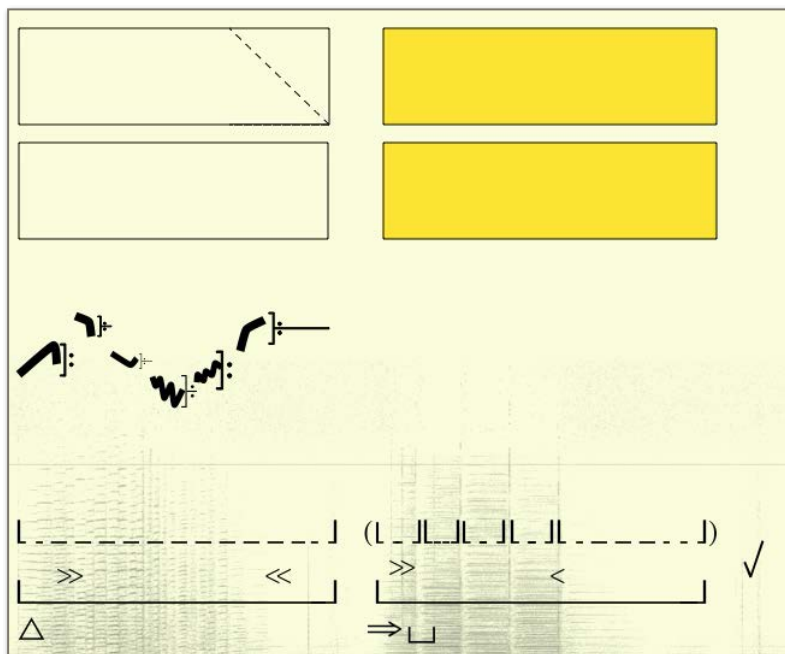

**Figure 6.11 - Angell 3'22''-3' 40'', 6th video, <http://bit.ly/2prw7y4><sup>135</sup>**

Three melodic fragments, as well as its inversions, are heard in successive orders throughout the first phrase of the second movement (fig 6.11). They are arranged in various heights that indicate a relative distance of pitch-register. Fragment B and its inversions are identified as a high interval-half tone structure (page 64-65). The figure depicts a motion of increasing and decreasing tendency for each new fragment. The performance is perceived with consecutive motions of less friction/flow that establishes a certain structure of object-fields. The next phrase-field consists of a chorale of major-chords, perceived with calmer dynamics and a reduced motion of less friction/flow. The contrasting musical elements is considered to shape a structure of question and answer; the question is interpreted as enfolded (phrase-field one), as it represents melodic chromatic-patterns (monophony), while the answer is interpreted as unfolded (phrase-field two), as it represents a consonant chorale (homophony). The transition from irregular to regular movement creates the perception of less friction in general flux-character. Noticeable silences mark a gap between these musical elements.

---

<sup>135</sup> Ibid, page 3, bar 1-3.



**Figure 6.12 - Alberdi 2'41''-2' 53'', 7th video, <http://bit.ly/2prw7y4><sup>136</sup>**

There are different factors that separates this interpretation (fig. 6.12) from the previous aural analysis (fig 6.11): Firstly, both phrase-fields is performed at a faster rate compared to the previous figure (6.11), which is illustrated (fig. 6.12) with the signs of fragments being smaller and object-fields more compact (second phrase-field). Secondly, the motion of melodic fragments is perceived as a united object-field (first phrase-field). Thirdly, less friction/flow is emphasized at the beginning and end of both phrases. Fourthly, both tendencies are illustrated as presence-oriented and a gap of silence is first provided after both phrase-fields.

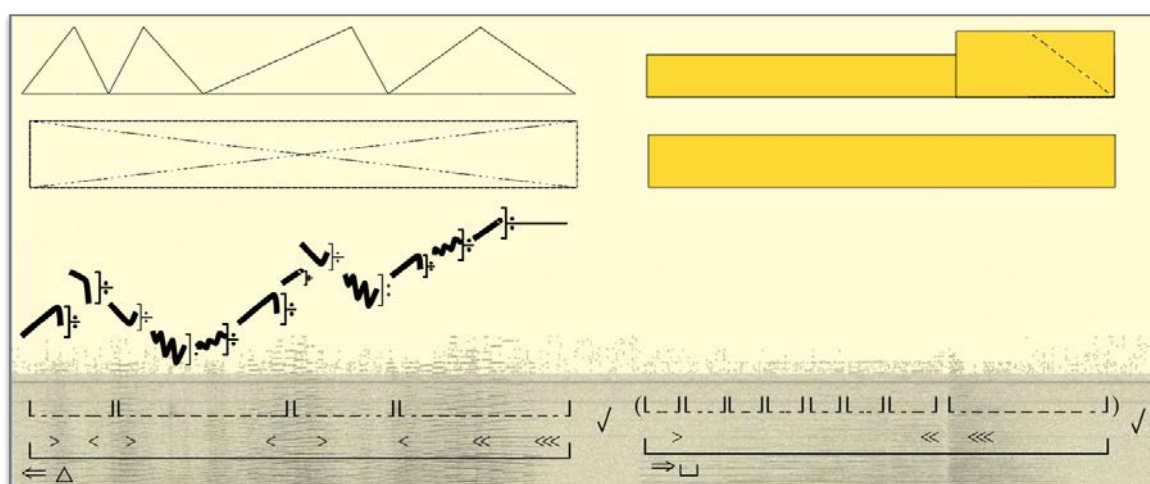

**Figure 6.13 - Angell 3'41''-4' 08'', 6th video<sup>137</sup>**

<sup>136</sup> Ibid.

<sup>137</sup> Ibid, page 3, bar 4-8 (ending before number 8).

A new fragment is perceived in the middle (fragment D), which also recurs at the end of the third phrase-field (first phrase in figure 6.13). The phrase has expanded in terms of fragments, tendencies and friction/flow.

Dynamic tendencies are still in a motion of increasing and decreasing, but are perceived with stronger increasing intensions. The fourth phrase (second phrase in fig. 6.13) has further expanded the dynamic energy and amount of object-fields, performed at a faster rate than before.

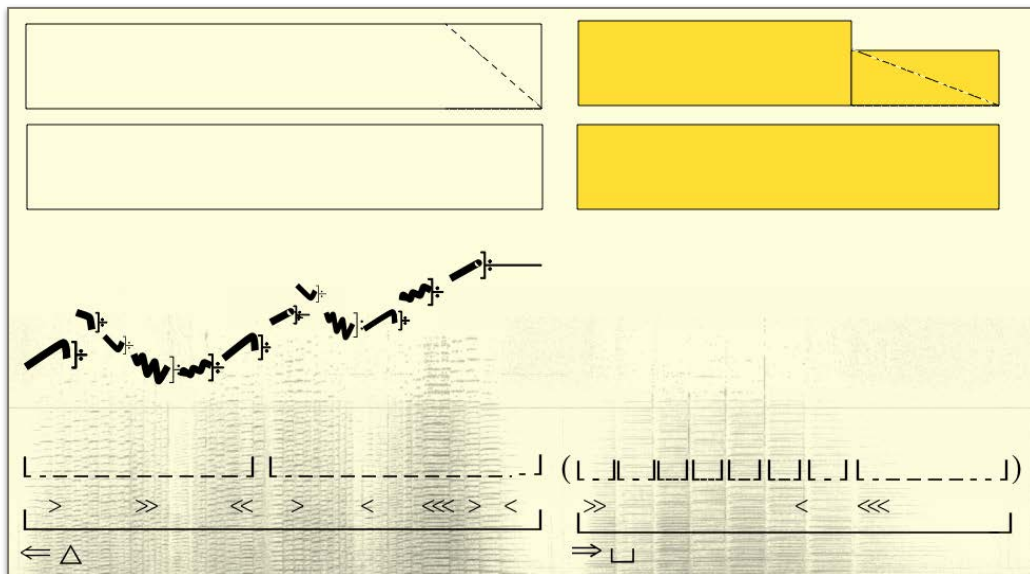

**Figure 6.14 - Alberdi 2'54''-3' 13'', 7th video<sup>138</sup>**

The relation of faster and slower rhythmical values is more intricate (fig. 6.14), creating a vigorous and irregular time-character (illustrated with flux). As such, the object-fields are perceived and interpreted as two parts. The third tendency (first tendency in figure 6.14) is similar to the first tendency of the movement (Fig. 6.12-Alberdi). The fourth tendency however (second tendency in figure 6.14), is identified as an opposite interpretive solution compared to Angell's performance (fig. 6.13); the figure (6.14 - Alberdi) starts with strong dynamics and ends with smaller dynamics at the remaining chord. While the other figure (6.13 - Angell) starts with smaller dynamics and ends with strong dynamics at the last chord.

<sup>138</sup> Ibid.

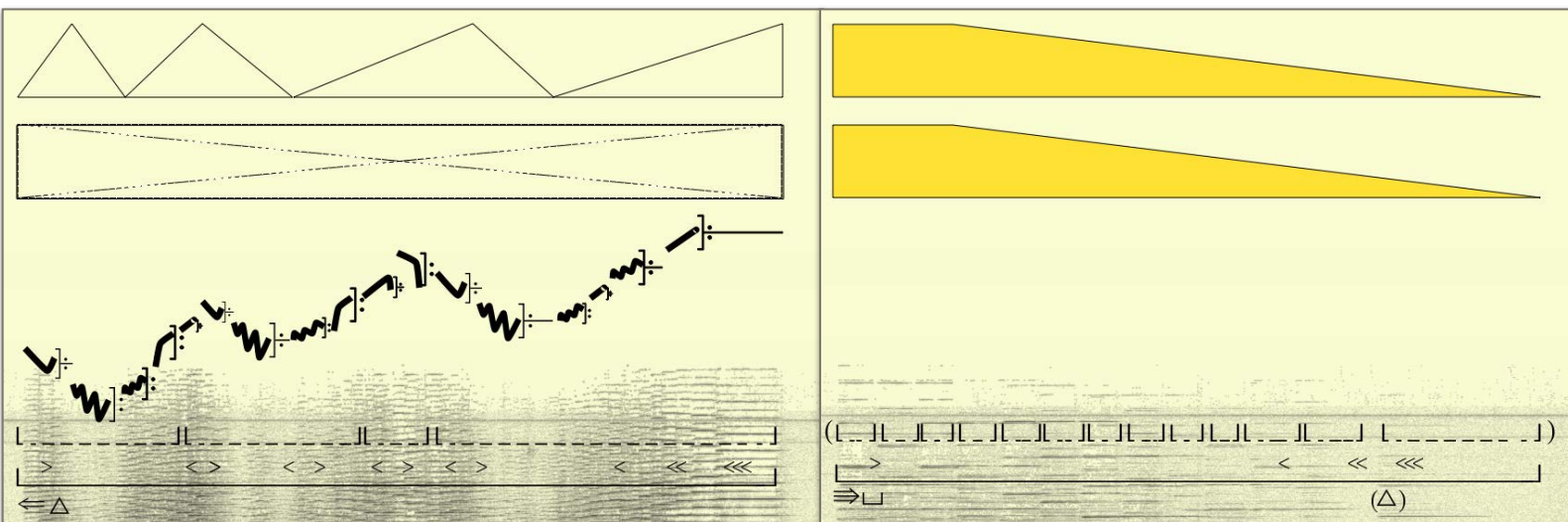
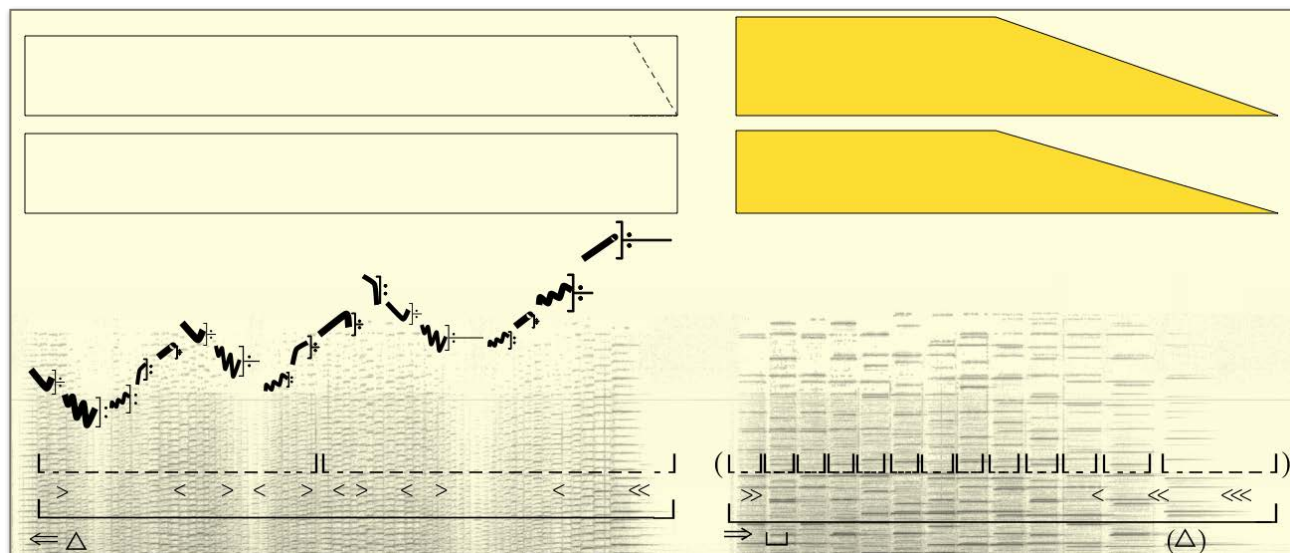

**Figure 6.15 - Angell 4'09''-4' 43'', 6th video<sup>139</sup>**

A further expansion of fragments is seen in the fifth phrase-field (first phrase in fig. 6.15).

The directions of tendencies are similar to the third phrase (fig. 6.13-Angell), except for an establishing initiative by ending with an increasing tendency (first phrase in fig. 6.15).

The figure (6.15) depicts an absence of the previous silences between the phrase-fields (fig. 6.11 and fig 6.13 - Angell). Therefore, the sixth phrase-field (second phrase in fig. 6.15) is heard with a quicker response illustrated as a stronger, decreasing tendency that dissolves in tempo (indicated by more friction), and ends with an enfolded indication in parenthesis to highlight the sudden shift from major-chords to a minor.



**Figure 6.16 - Alberdi 3'14''-3' 39'', 7th video<sup>140</sup>**

<sup>139</sup> Ibid, page 3, number 8, bar 9 - page 4, bar 5 (ending before number 10).

<sup>140</sup> Ibid.

The fifth phrase-field (first phrase in fig. 6.16) continues in a stable tendency, similar to previous segments of melodic fragments (fig. 6.12 and 6.14 - Alberdi), that ends with a faint declining tendency. The last note is perceived as rounded off (fig. 6.16). However, this faint declining tendency (fig. 6.16) is the opposite choice of interpretation, compared to the initiative of an increasing tendency performed by Angell (fig. 6.15). The fragments continue to be played faster than Angell's example, again creating a perception of longer and fewer structures of object-fields. The sixth phrase (second phrase in fig. 6.16) has a significant longer, stable tendency, and the chords are played faster compared to Angell (fig. 6.15). Still, they are similar motions of dissolvment aimed towards the remaining minor-chord (enfold).

### 6.5.2 Exosemantic Interpretation - 2nd movement - Angell versus Alberdi

<b>Common semantic elements</b>				
<b>Signifier</b>	<b>Semiosis</b>	<b>Signified-&gt;Signifier</b>	<b>Semiosis</b>	<b>Signified</b>
Melodic fragments: Chromatics and monophony (Enfold) (L <sub>2</sub> )	CMPAR +INFER (F <sub>2</sub> )	Individual pain	CONNOT (F <sub>2</sub> )	Sermoning
Consonant chorale (Unfold) (L <sub>2</sub> )	CONNOT (F <sub>2</sub> )	Collective belief	CONNOT (F <sub>2</sub> )	Soothing individual pain
Expansion of musical elements (L <sub>2</sub> ) + (L <sub>3</sub> )	CMPAR (F <sub>1</sub> )	Increasing effort	CMPAR+INFER (F <sub>2</sub> )	Passion
Third chorale as strong, decreasing tendency (L <sub>3</sub> )	CMPAR +INFER (F <sub>2</sub> )	Certain, then uncertain	CONNOT (F <sub>2</sub> )	Hope that turns in to torment
<b>Andreas Angell</b>				
Frequent noticeable silences between fields, slower tempo and frequent alterations of increasing and decreasing tendencies (L <sub>1</sub> ) + (L <sub>2</sub> ) + (L <sub>3</sub> )	CMPAR +INFER (F <sub>1</sub> )	Hesitant	CONNOT (F <sub>1</sub> )	Fragile
<b>Iñaki Alberdi</b>				
Infrequent use of silence between fields, faster tempo and frequent presence oriented tendencies (L <sub>1</sub> ) + (L <sub>2</sub> ) + (L <sub>3</sub> )	CMPAR +INFER (F <sub>1</sub> )	Confident	CONNOT (F <sub>1</sub> )	Vigorous

### 6.6.1 Aural analyses: 3rd movement - opening

Performers: Geir Draugsvoll/Friedrich Lips

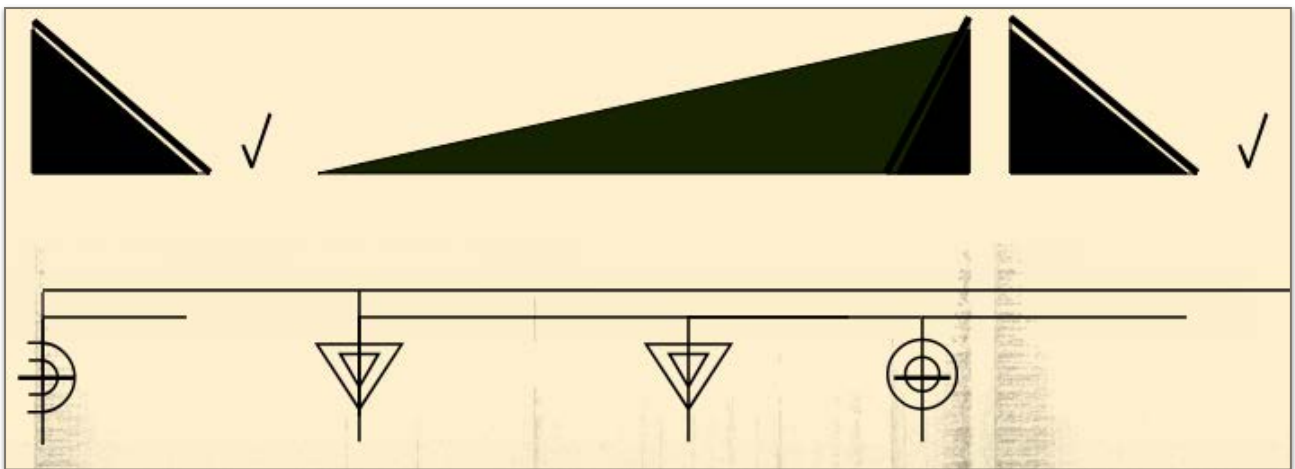

**Figure 6.17 - Draugsvoll 0'01''-0' 20'', 8th video, <http://bit.ly/2prw7y4><sup>141</sup>**

The figure (6.17) depicts three different form-building elements of textures, as the first opening element represents the partitioned half of the third element. A motion of chained form-elements is perceived and illustrated as a group:

**Figure 6.18 - Motion of chained form-elements**

<sup>141</sup> Ibid, page 7, bar 1-13 (ending before number 14).

The first form-element (marked relatively simple) is rhythmically characterized by three articulated *sforzandi* together with stable iteration of the complex texture (fig. 6.18).

In contrast of the previous consideration of melodic fragments, which was not limited to specific pitches and durations, these elements are defined through its specific entirety.

The opening half of the second form-element (marked relatively simple) is characterized by the *successive* change of pitch and two articulated accents, while the second half of the form-element represents the *consecutive* change of pitch and impulse articulation.<sup>142</sup>

The third form-element (marked distinct, very simple) is characterized by an ascending cluster and the other half is perceived as an irregular descending cluster.

The interpretation by Draugsvoll is heard without the articulated bellow-shake indicated in the score (1 - v).

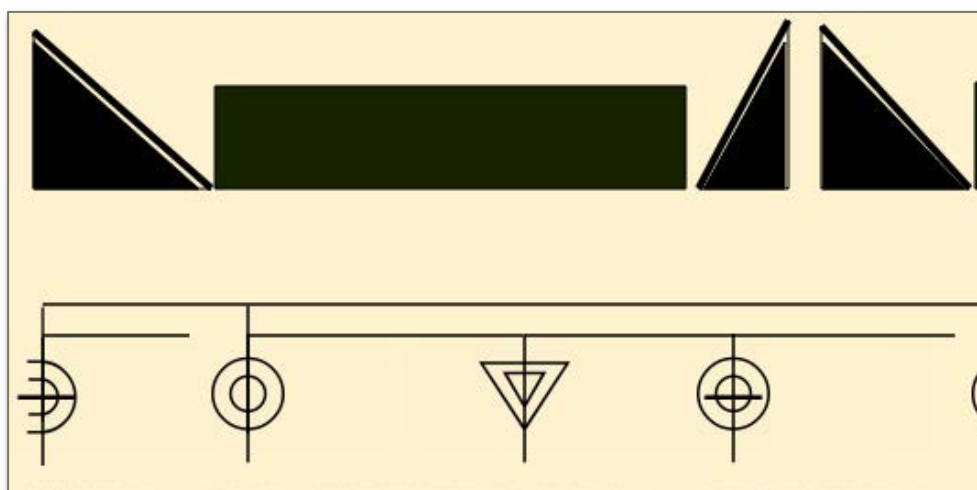

**Figure 6.19 - Lips 6'07''-6' 21'', 9th video, <http://bit.ly/2prw7y4><sup>143</sup>**

In this interpretation (fig. 6.19) the analysis does not separate the opening partitioned element with silence, neither after the first motion of form-groups (united form-elements through the prolongation line). What previously was identified as a relative simple element after the partitioned opening is now defined as a very simple element; it is harder to distinguish the three articulated *sforzandi* from the iterated stable object.

<sup>142</sup> *Consecutiveness* situates the close succession of pitches without gaps, while *successiveness* is preferred to illustrate a certain order. For instance; 1, 2 and 3 are consecutive numbers, while 1, 2 and 4 are successive numbers.

<sup>143</sup> Ibid.





**Figure 6.20 - Score excerpt**

This may be caused by the performer's intention to achieve both the indicated bellow-shake and tempo suggestion 'Presto' in the score (fig. 6.20), as this performance is played faster than the first example. Tendencies of the two elements centered in the analysis (fig. 6.19), are heard as presence-oriented and the form-elements are perceived as a transformation from the shaking texture (very simple element) to the articulated texture (relatively simple element).

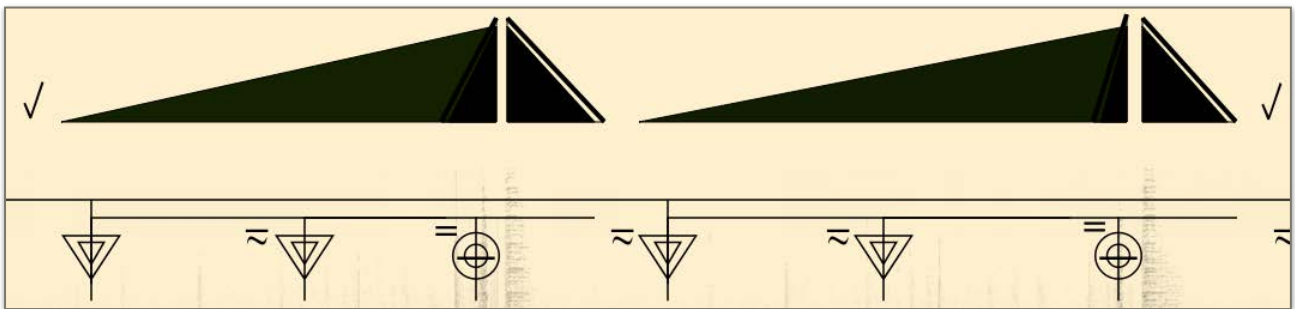

**Figure 6.21 - Draugsvoll 0'21''-0' 50'', 8th video<sup>144</sup>**

The second motion of form-groups (first chained motion in figure 6.21) continues with the three form-elements in order, with slightly varied recurrence. The first change occurs in the second relatively simple element, as it consists of an additional texture. The third motion (second motion in fig. 6.21) consists of change in both relatively simple elements, as the first element changes in pitch throughout its appearance. The second element continues to include an additional texture. The very simple element is heard with exact similarity. The transition between the second and third motion (first and second motion in fig. 6.21) is performed without the anticipated separation of silence which was previously established (Fig. 6.17 and 6.21-Draugsvoll).

<sup>144</sup> Ibid, page 7, number 14, bar 14 - page 8, bar 10 (ending before number 16).

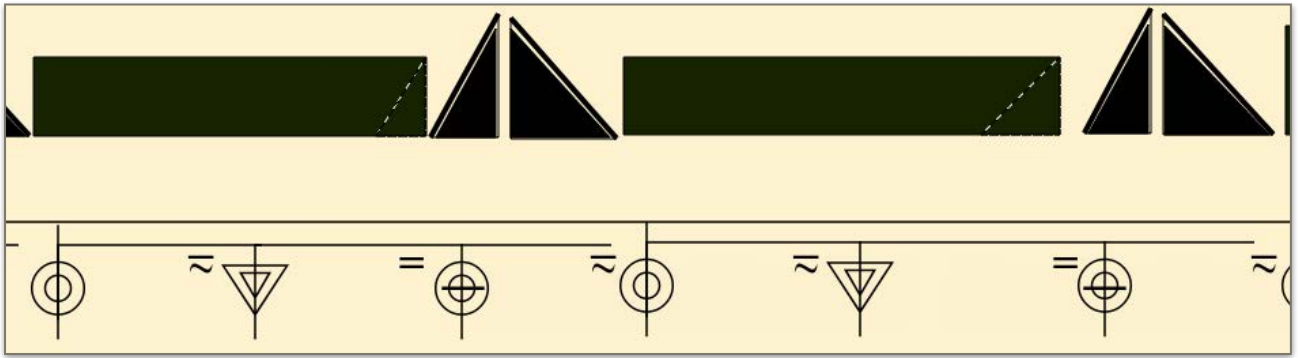

**Figure 6.22 - Lips 6'21''-6' 47'', 9th video<sup>145</sup>**

This example follows the same changes of form-processes and continues as presence-oriented tendencies of the first elements, but with a slight, increasing tendency at its end (faint).

The chained motions of form-elements persists collectively with no silence between.

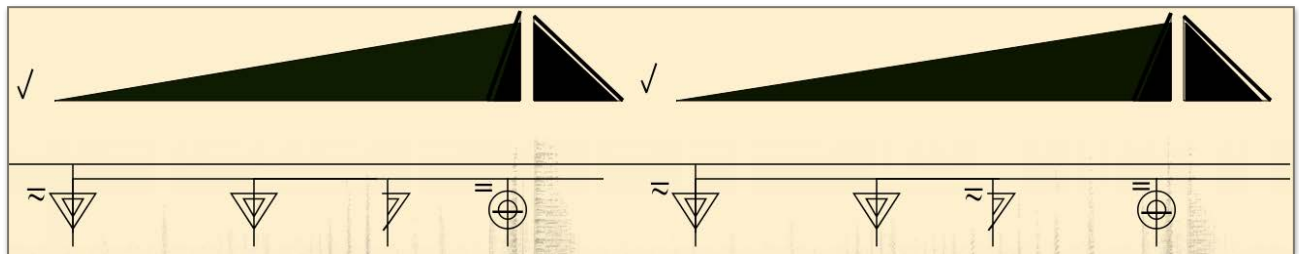

**Figure 6.23 - Draugsvoll 0'51''-1' 27'', 8th video<sup>146</sup>**

The elements continue to slightly vary but in a different manner: the third element appears as partitioned from a lower pitch-register after its recurrence, making the chained motion of elements expand further (fig. 6.23). The fifth motion (second in fig. 6.23) is perceived with the partitioned element as expanded, as it consists of two additional textures.

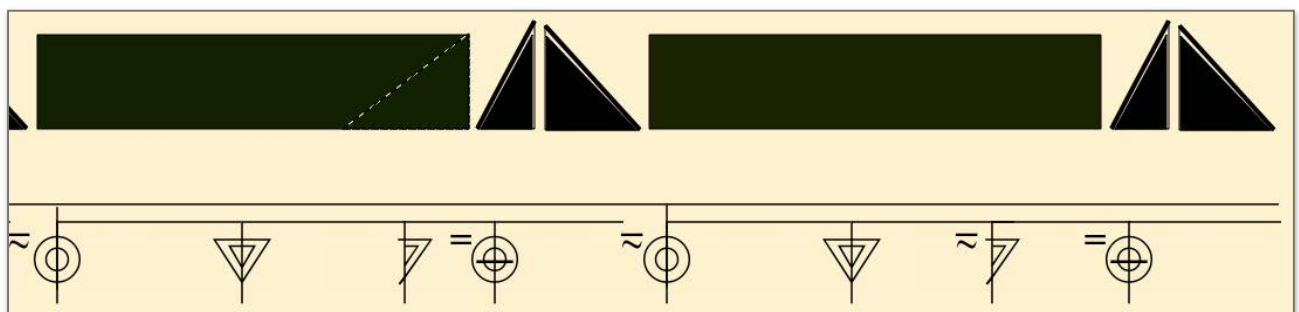

**Figure 6.24 - Lips 6'47''-7' 17'', 9th video<sup>147</sup>**

<sup>145</sup> Ibid.

<sup>146</sup> Ibid, page 8, number 16, bar 10 - page 9, bar 6 (ending before number 18).

<sup>147</sup> Ibid.

The stable dynamic tendency is perceived louder than before (fig. 6.24), compared to previous segments (fig. 6.19 and fig. 6.22 - Lips), indicated by a larger present-oriented figure.

Where the analysis of Draugsvoll's performance shows one exception of separated silences, the analysis of Lip's performance illustrate an unhindered collection of tendencies.

### 6.6.2 Exosemantic Interpretation - 3rd movement - Draugsvoll versus Lips

<b>Common semantic elements</b>				
<b>Signifier</b>	<b>Semiosis</b>	<b>Signified-&gt;Signifier</b>	<b>Semiosis</b>	<b>Signified</b>
Irregular descending cluster (L <sub>3</sub> )	CMPAR (F <sub>1</sub> )	Disruption	CMPAR+ CONNOT (F <sub>2</sub> )	Submission
Motion of chained form-elements (L <sub>3</sub> )	CONNOT (F <sub>2</sub> )	Entanglement-> Struggling-> Failed effort	CONNOT (F <sub>2</sub> )	Sinful, Cry for help
Extension of textures (L <sub>3</sub> )	CMPAR (F <sub>1</sub> )	Increasing effort	CMPAR +INFER (F <sub>2</sub> )	Passion
<b>Geir Draugsvoll</b>				
Frequent noticeable silences between chained elements, medium tempo and increasing tendencies through chained motions	CMPAR +INFER (F <sub>1</sub> )	Focused	CONNOT (F <sub>2</sub> )	Powerful
<b>Friedrich Lips</b>				
Connected motions of chained elements, fast tempo and presence oriented tendencies through chained motions	CMPAR +CONNOT (F <sub>2</sub> )	Trembling	CONNOT (F <sub>2</sub> )	Afraid

### 6.7.1 Aural analyses: 4th movement - opening

Performers: Andreas Angell/Friedrich Lips



The fourth movement of the sonata may be considered the climatic conclusion of anticipation, because of its sudden change from musical developments of separated parts, to a greater and concentrated chorale that develops uninterrupted by other elements. Examples of musical development of separated parts could be identified in the first movement with the cluster/chord versus the air sounds, as well as the successive chords/chorale and the tritone interval, the second movement with the melodic fragments versus the chorale and the third movement with the iterated cluster (small range) versus the cluster glissandi (large range).

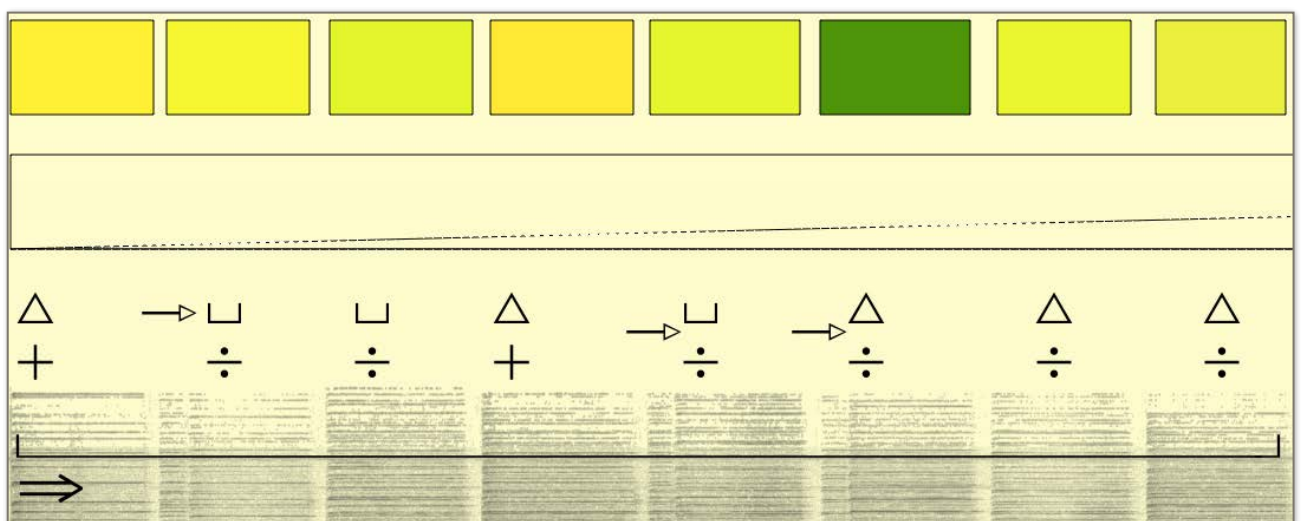
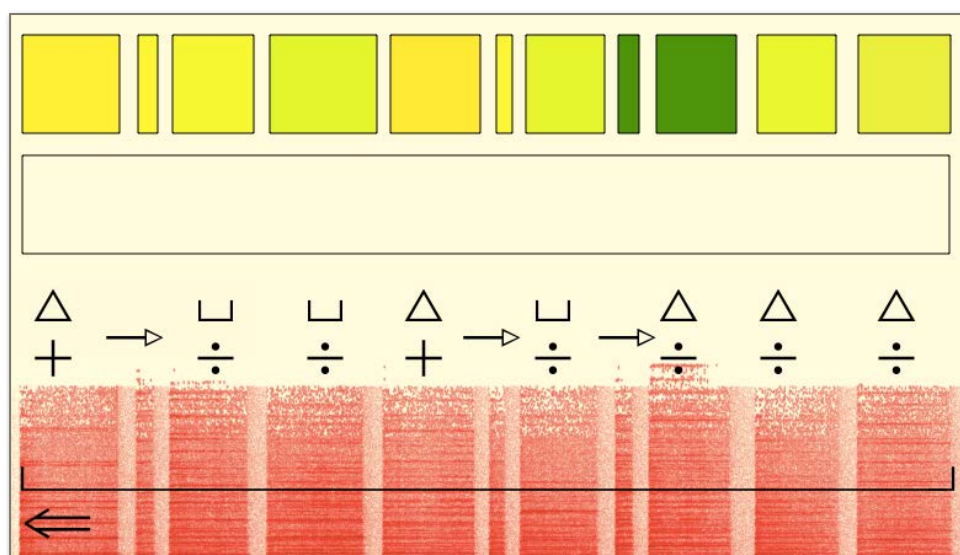

Figure 6.25 - Angell 13'38''-14' 09'', 10th video, <http://bit.ly/2prw7y4><sup>148</sup>

<sup>148</sup> Ibid, page 13, bar 1-8.

This analysis (fig. 6.25) depicts the duration of stable tendencies of each chord and its harmonic color.<sup>149</sup> The focus of this analysis is emphasized to illuminate relations between each chord of the three-first phrase-fields of the movement. As this is intently related to harmonic dimensions, a comparison of a different recording will only be made of the first phrase-field to illuminate differences of dynamic and durational interpretation.

The first enfolded symbol represents the minor-chord and the sign indicating concord represents clear consonance. It further transforms in to a dissonant major-chord, perceived as brighter and unfolded. The first phrase-field is an apparent conflict between the concord minor (enfold) and discord major (unfold) harmonies, which ends with clustered and enfolded textures in discord. A flux character of less friction is interpreted in the analysis, as each tendency has limited suspension and interruptions, thus providing a perception of a stable harmonic line, much like a harmonized continuous melody.

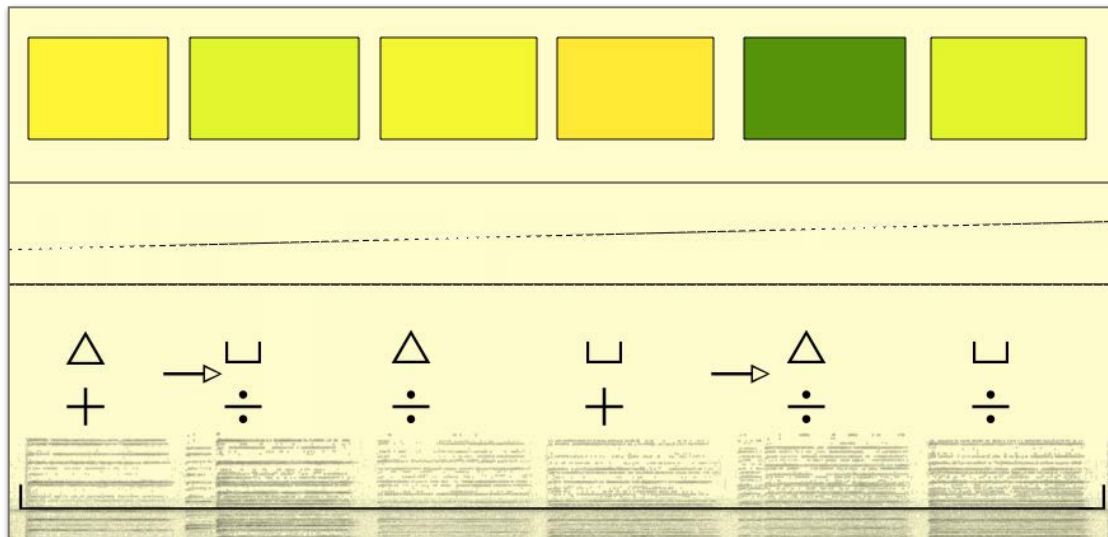

**Figure 6.26 - Lips 11'48''-12' 10'', 11th video, <http://bit.ly/2prw7y4><sup>150</sup>**

This performance is faster (fig. 6.26), as the separated tendencies are shorter than the previous analysis (fig. 6.25 - Angell). The indicated transformations (arrows) of enfold-unfold are articulated as separated tendencies with suspension, providing a perception of more friction in flux character (fig. 6.26).

<sup>149</sup> The depiction of harmonic colors is mainly kept for aesthetic purposes, as the signs for *discord-concord* clarifies dissonant or consonant relations between the harmonic progression.

<sup>150</sup> Gubaidulina, *Sonate: Et Exspecto*, page 13, bar 1-8.



**Figure 6.27 - Angell 14'09''-14' 43'', 10th video<sup>151</sup>**

The second phrase-field (first phrase-field in fig. 6.27) summarize its previous motions from concord-enfold to discord-unfold, concluding at a discord-enfolded harmony. The fourth harmony however, is perceived as a consonant major chord (concord-unfold) that has not yet been presented, before it moves further to a discord-enfolded harmony. In contrast of the first phrase-field (fig. 6.25), the last chord settles as a discord-unfolded harmony.

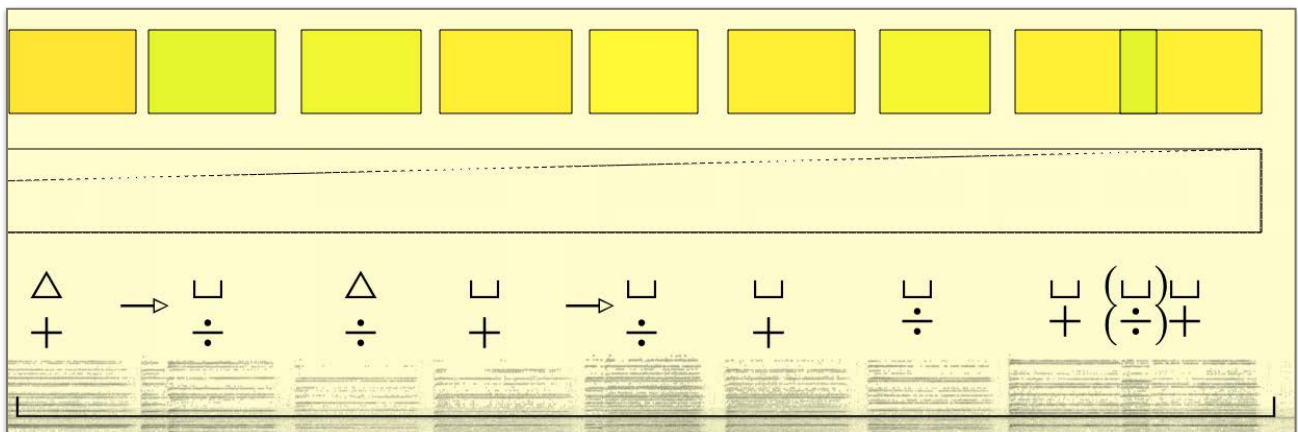

**Figure 6.28 - Angell 14'43''-15' 08'', 10th video<sup>152</sup>**

The third phrase-field (first phrase-field in fig. 6.28) marks the end of the first part in the fourth movement. It starts with repeating the same four motions as the previous phrase-field (fig. 6.27) in terms of contextual meanings. The harmonic dimensions develops, as it remains in unfolded major-

<sup>151</sup> Ibid, page 13, bar 9-14 (ending before number 26).

<sup>152</sup> Ibid, page 13, number 26, bar 15-23.

harmonies for the rest of the phrase. Further, it is the play between concord-discord of unfolded textures that is expressed in the analysis. The end is established by the concord-unfolded harmony.

### 6.7.2 Exosemantic Interpretation - 4th movement - Angell versus Lips

<b>Common semantic elements</b>				
<b>Signifier</b>	<b>Semiosis</b>	<b>Signified-&gt;Signifier</b>	<b>Semiosis</b>	<b>Signified</b>
Concord-minor harmony to discord-major harmony (L <sub>2</sub> )	CMPAR +CONNOT (F <sub>2</sub> )	Prominent sorrow -> Longing hope		
Discord-major harmony to discord-minor harmony (L <sub>2</sub> )	CMPAR +CONNOT (F <sub>2</sub> )	Hope -> Sinfulness		
Concord-major harmony to clustered chord (enfold) (L <sub>2</sub> )	CMPAR +CONNOT (F <sub>2</sub> )	Joy -> Despair		
Discord-major harmony to concord-major harmony (L <sub>2</sub> )	CMPAR +CONNOT (F <sub>2</sub> )	Hope -> Forgiveness		
<b>Andreas Angell</b>				
Equal tendencies of motions, more flow of character (L <sub>2</sub> ) + (L <sub>3</sub> )	CMPAR +INFER (F <sub>1</sub> )	Uninterrupted	CMPAR +CONNOT (F <sub>2</sub> )	Patient
<b>Friedrich Lips</b>				
Unequal tendencies of motions, more friction of character (L <sub>2</sub> ) + (L <sub>3</sub> )	CMPAR +INFER (F <sub>1</sub> )	Interrupted	CMPAR +CONNOT (F <sub>2</sub> )	Anxious

### 6.8.1 Aural analyses: IV - ending

Performers: Geir Draugsvoll/ Friedrich Lips

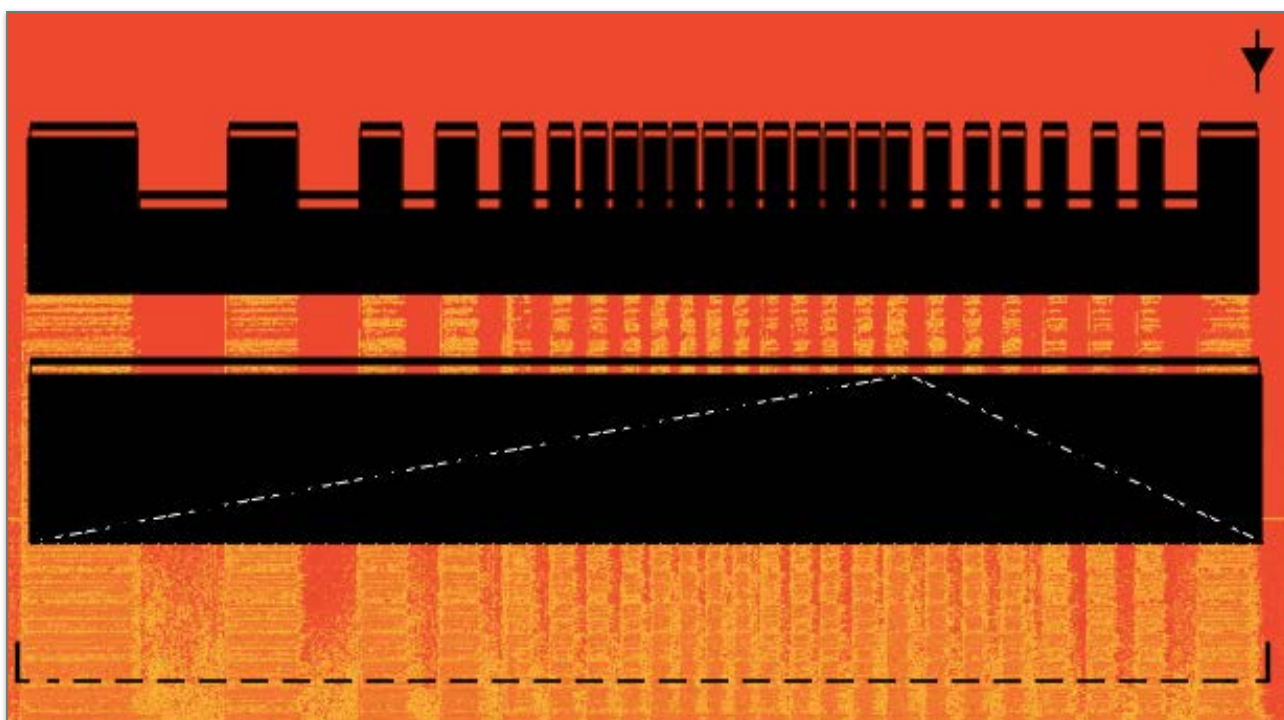

**Figure 6.29 - Draugsvoll 3'22''-3' 39'', 12th video, <http://bit.ly/2prw7y4><sup>153</sup>**

The analysis (fig. 6.29) illustrates the culmination of the fourth movement. Blackness indicates a large range of clusters, performed as emphasized tendencies. The different heights of tendencies indicate the perceptual separation of the accordion's manuals, where the left manual (bass-side) is perceived with less dynamics (lower register of clusters) compared to the right manual (treble-side), which is perceived with higher dynamics (higher register of cluster).

Though it might seem as an excessive notation of dynamic forms, it serves as a synopsis of how these musical elements are interpreted. This interpretation uses a large amount of acceleration to the alternation of clusters, ending with a longer duration on the last cluster (treble-manual).

The abrupt ending is perceived as a separated point (accent), ending the object-field.

---

<sup>153</sup> Ibid, page 15, bar 5 (extended bar).



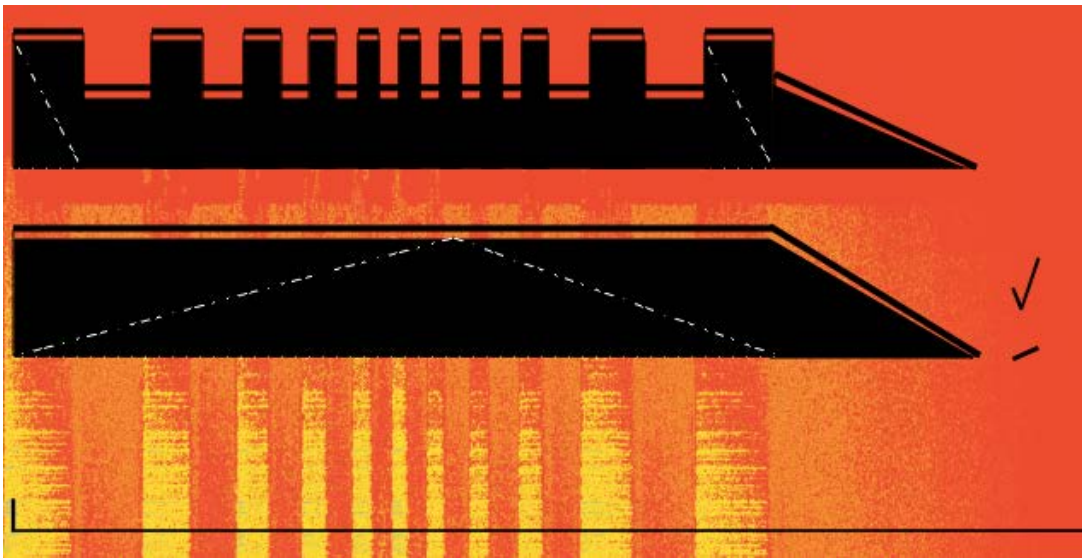

**Figure 6.30 - Lips 14' 39''-14' 56'', 13th video, <http://bit.ly/2prw7y4><sup>154</sup>**

This analysis (fig. 6.30) shows less than half of the clusters performed in the previous figure (6.29 - Draugsvoll) and focuses less on rapid exchange between the textures. The peak of the faint tendency is centered, opposite to the previous figure (6.29). The ending is very different, as the clusters are played in the bass-manual and as a decreasing tendency (fig. 6.30). As the cluster dissolves, silence is interpreted as a bridged positioning and the phrase-field is perceived as enduring.

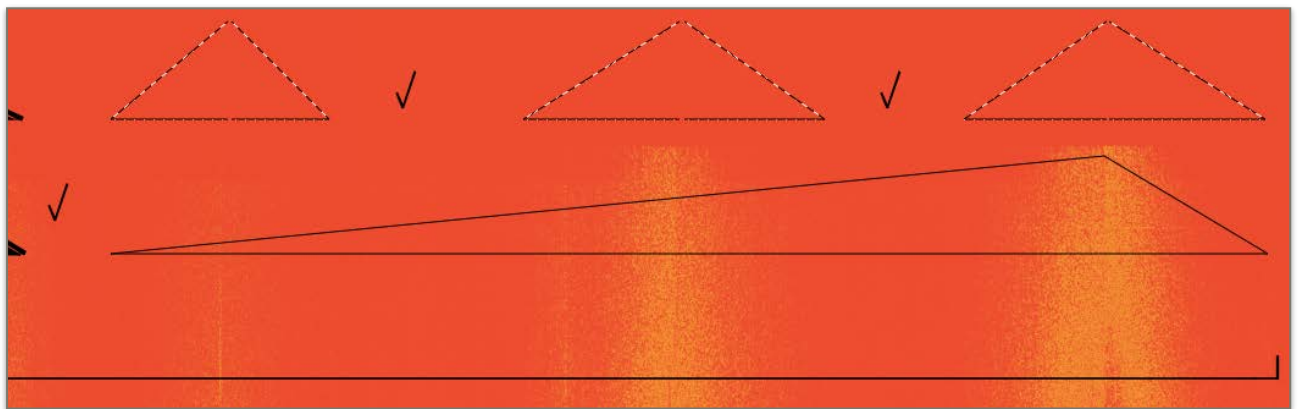
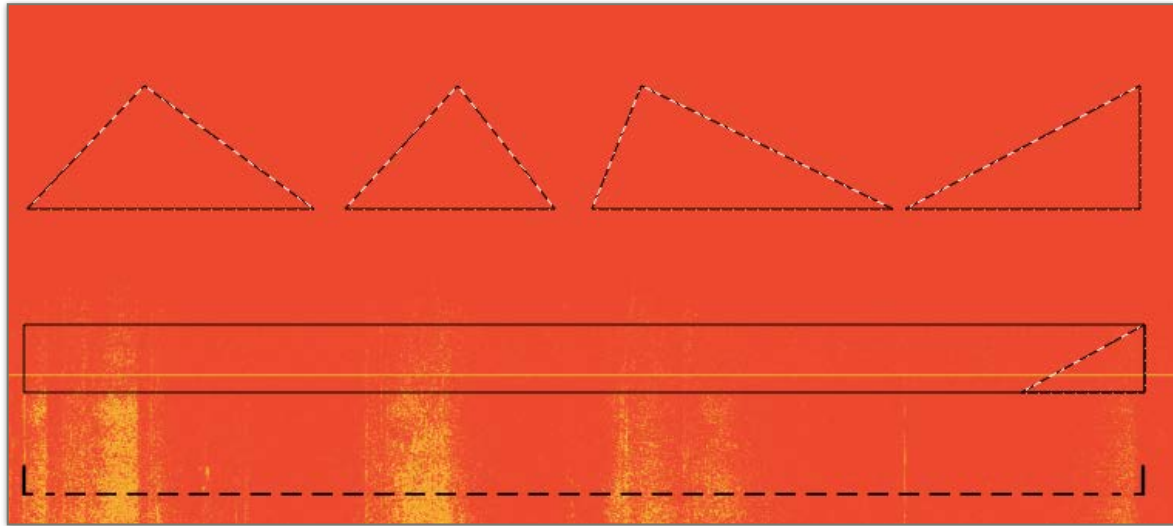

**Figure 6.31 - Lips 14'57''-15' 24'', 13th video<sup>155</sup>**

The analysis (fig. 6.31) illustrates the continuation of Lips' performance, as air sounds gradually appear from silence. This creates a perception of phrase-field focus, as the air sounds reappear with stronger tendencies (also seen as a slight yellow color in the spectrograph), thus creating a developing continuum.

<sup>154</sup> Ibid.

<sup>155</sup> Ibid, page 15, number 30, bar 6-11 (end).



**Figure 6.32 - Draugsvoll 3' 39''-4' 00'', 12th video<sup>156</sup>**

In this figure (6.32) the air sounds are perceived as a presence-oriented tendency in the lower dynamic model, as they are not reappearing with significant stronger tendencies (also seen as a slight yellow color in the spectrograph). The contrast of the previous abrupt ending of the loud complex texture to the sudden change of air-sounds (fig. 6.29), establishes a perception of object-field focus.

### 6.8.2 Exosemantic Interpretation - 4th movement - Draugsvoll versus Lips

<b>Common semantic elements</b>				
<b>Signifier</b>	<b>Semiosis</b>	<b>Signified-&gt;Signifier</b>	<b>Semiosis</b>	<b>Signified</b>
Alternating clusters (L <sub>1</sub> )	CMPAR (F <sub>2</sub> )	Flashing lights	CONNOT (F <sub>2</sub> )	Superior force
Air sounds (L <sub>1</sub> )	CMPAR (F <sub>1</sub> )	Breathing	CONNOT (F <sub>1</sub> )	Breeze
<b>Geir Draugsvoll</b>				
Quicker alternation of more textures, connected motions of air sounds and object-field focus (L <sub>1</sub> )+(L <sub>3</sub> )	CMPAR +INFER (F <sub>1</sub> )	Extrovert	CONNOT (F <sub>2</sub> )	Struggle
<b>Friedrich Lips</b>				
Slower alternation of less textures, noticeable silences between air sounds and phrase-field focus (L <sub>1</sub> )+(L <sub>3</sub> )	CMPAR +INFER (F <sub>1</sub> )	Introvert	CONNOT (F <sub>2</sub> )	Pain

<sup>156</sup> Ibid.

### 6.9.1 Aural analyses: V - Whole

Performers: Iñaki Alberdi/Friedrich Lips

The final movement may be regarded as the epilogue of the sonata, as it brings closure to the work after its conclusive fourth movement. In this context I wish to illuminate form-building elements and processes of the movement as a whole, which is a dimension that has not yet been considered in my endosemantic analyses of Gubaidulina. The last movement seems as an appropriate choice for departure, not only being the shortest of all five movements, but because of its apparent enigmatic structure. I have performed and heard this movement multiple times, often with the impression of a continuous melodic framework that deviate through different imitating patterns.

Therefore, an exception is made to not restrict the analysis to exclusive examples of the movement. As such, Iñaki Alberdi's performance as well as Friedrich Lips', will be analyzed to clarify form-building elements of the movement and how these interpretations is perceived and analyzed differently.

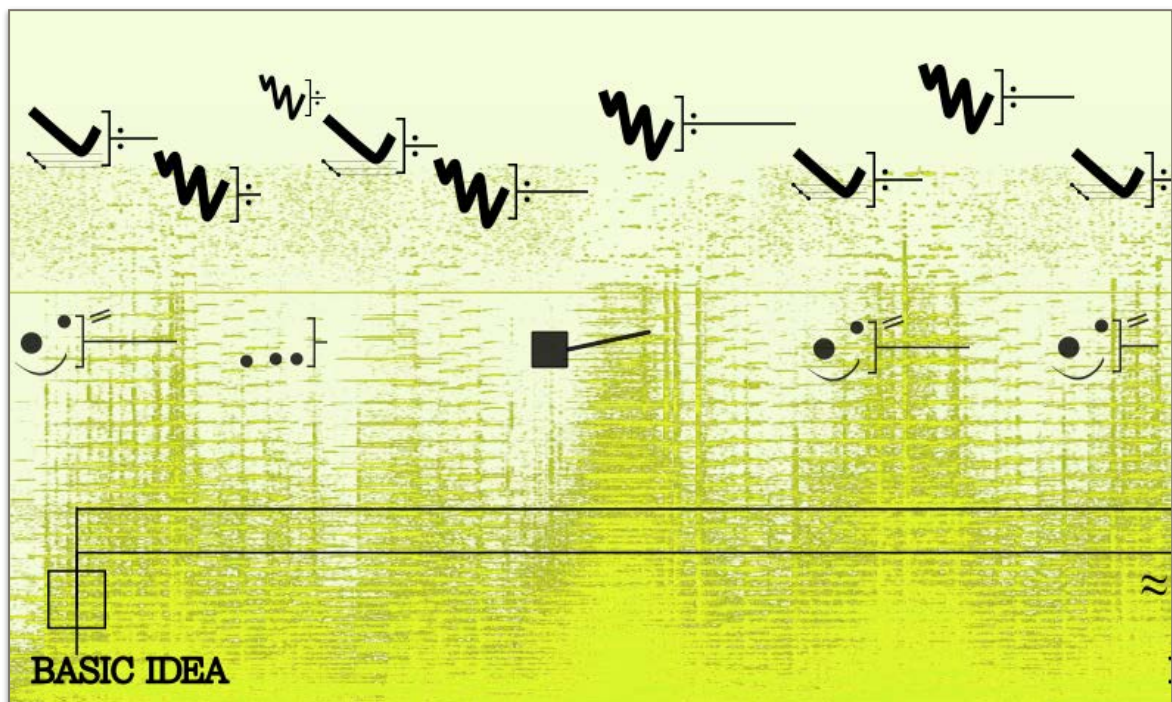

Figure 6.33 - Alberdi 0'00''-0' 08'', 14th video, <http://bit.ly/2prw7y4><sup>157</sup>

The analysis (fig. 6.33) consists partly of melodic fragments and level one sound-objects. The signs of spectromorphology are indicated with less opacity; it is perceived as supplements to the melodic fragments and are not equally important for the perception of form-building elements (background layer). Therefore, it is the melodic fragments that establish the criteria of emerging form-elements and processes in this context (foreground layer).

<sup>157</sup> Ibid, page 16, line-staves 1-2.

In contrast of the second movement, the melodic fragments appear less various and more recurrent. One might consider the musical elements of this movement as 'fragments of fragments' that previously has been established as more diverse. For instance, fragment C (page 65) never occurs in the last movement and fragment B is reduced to a whole tone-half tone structure (page 64-65). The sound-objects ( $L_1$ ) are identified as trills, cells (few rapid pitches) and cluster-glissandi.

The alternating orders of fragment A and B illustrated in the example (fig. 6.33) are perceived as a *basic idea*, as it repeatedly will emerge throughout the movement in different registers, similar to a rondo-form. The form-element is perceived as a relatively complex element, with the first-five fragments indicating the first half and the last-four fragments indicating the other .

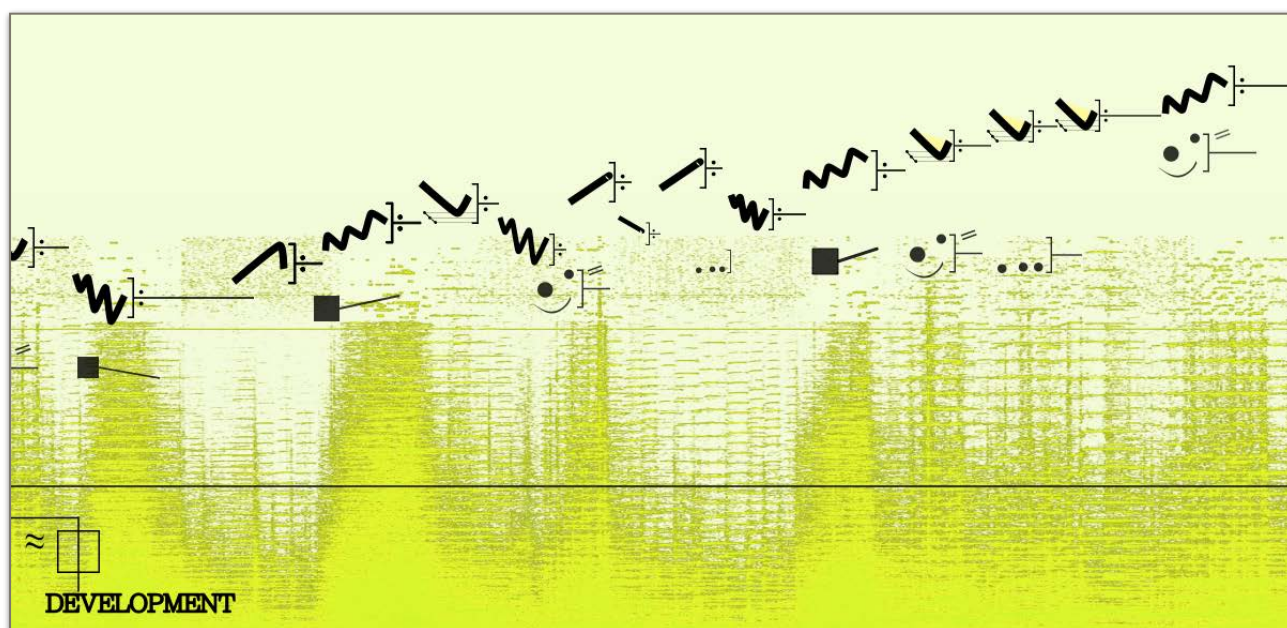

**Figure 6.34 - Alberdi 0'09''-0' 20'', 14th video<sup>158</sup>**

Further, a form-element is interpreted as a *development* and is perceived with a remote similarity to the previous element (fig. 6.34). This development presents other fragments, such as the inversions of the two-fragments of the B.I. (basic idea). Chromatic fragments (fragment D) are centered in the analysis. The structure of fragments are intricate compared to the B.I., as a development of a theme often is, but is still perceived as a relatively complex element; the fragments shaping musical lines are not perceived irregular in an unpredictable manner. The first fragment of the B.I. appears thrice in the end of the development, thus may be considered as an insisting play with the aural expectation of the basic idea.

<sup>158</sup> Ibid, page 16, line-staves 3-5.

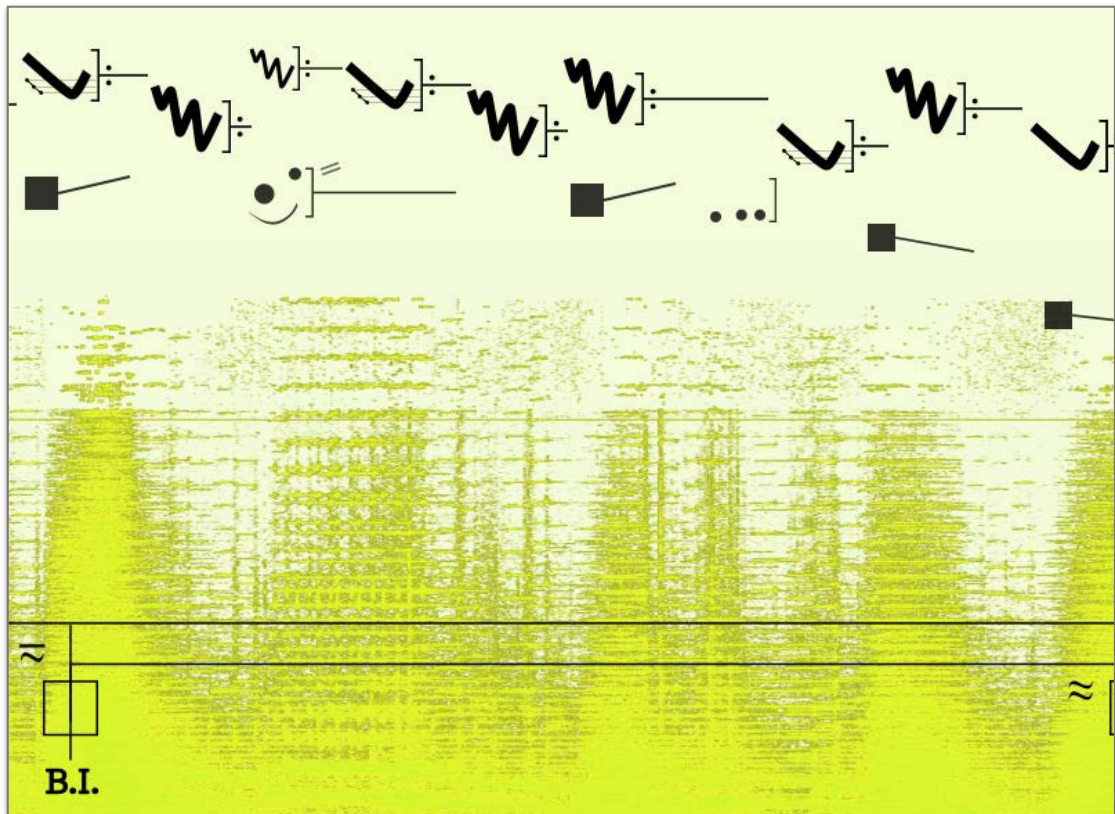

Figure 6.35 - Alberdi 0'20''-0' 28'', 14th video <http://bit.ly/2prw7y4><sup>159</sup>

The B.I. is perceived in a higher register (with different supplementing sound-objects), establishing a process of great similarity (fig. 6.35).

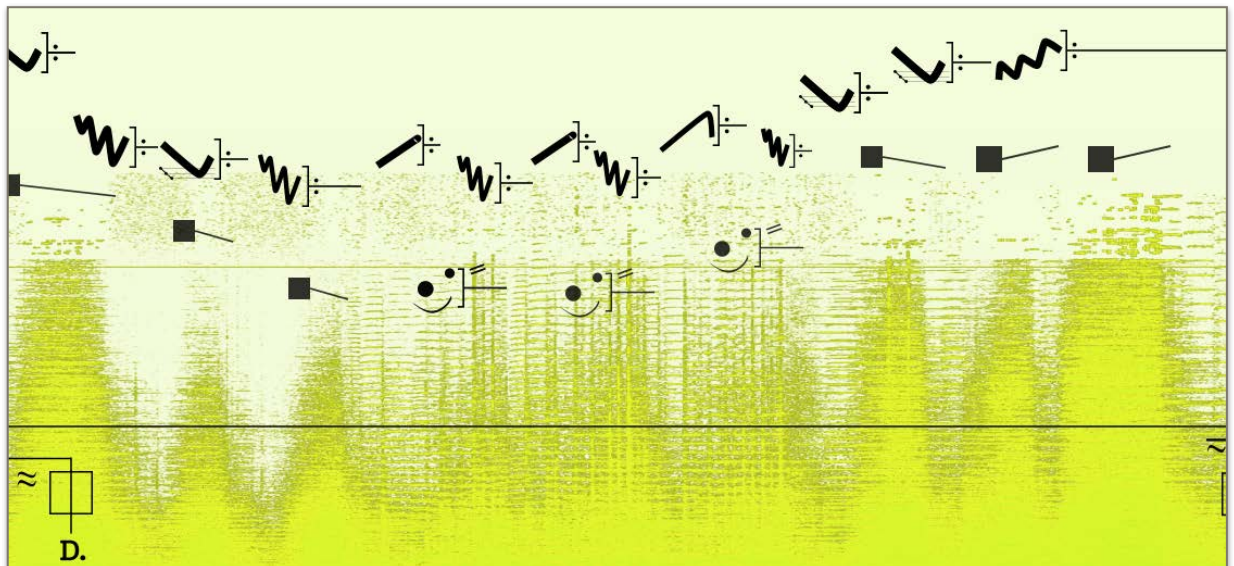

Figure 6.36 - Alberdi 0'28''-0' 38'', 14th video <http://bit.ly/2prw7y4><sup>160</sup>

<sup>159</sup> Ibid, page 17, line-staves 1-3.

<sup>160</sup> Ibid, page 17, line-staves 3-5.

The development is varied compared to its previous appearance and represents a process of remote similarity (fig. 6.36).

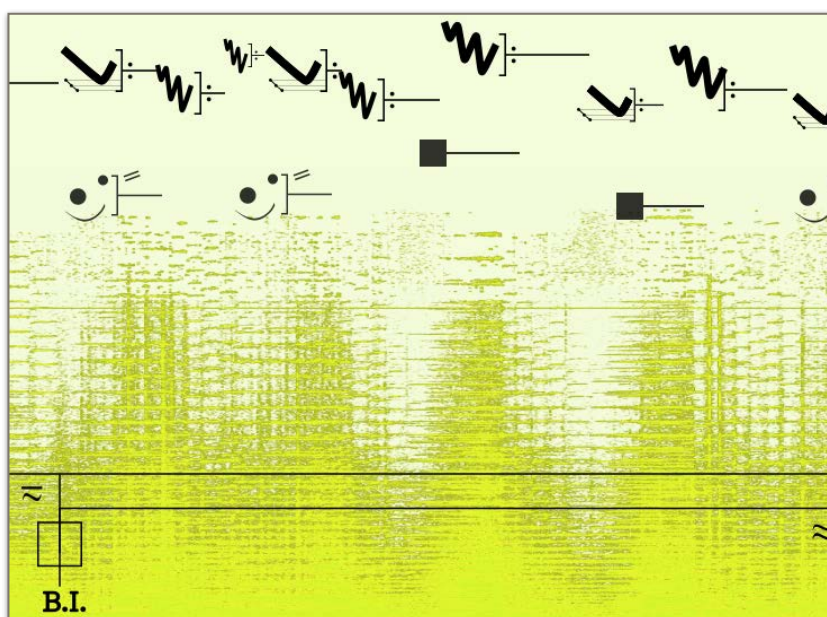

Figure 6.37 - Alberdi 0'38''-0'46'', 14th video <http://bit.ly/2prw7y4><sup>161</sup>

The B.I. is heard in a different pitch-register and clusters appear for the first time with stable energy (fig. 6.37).

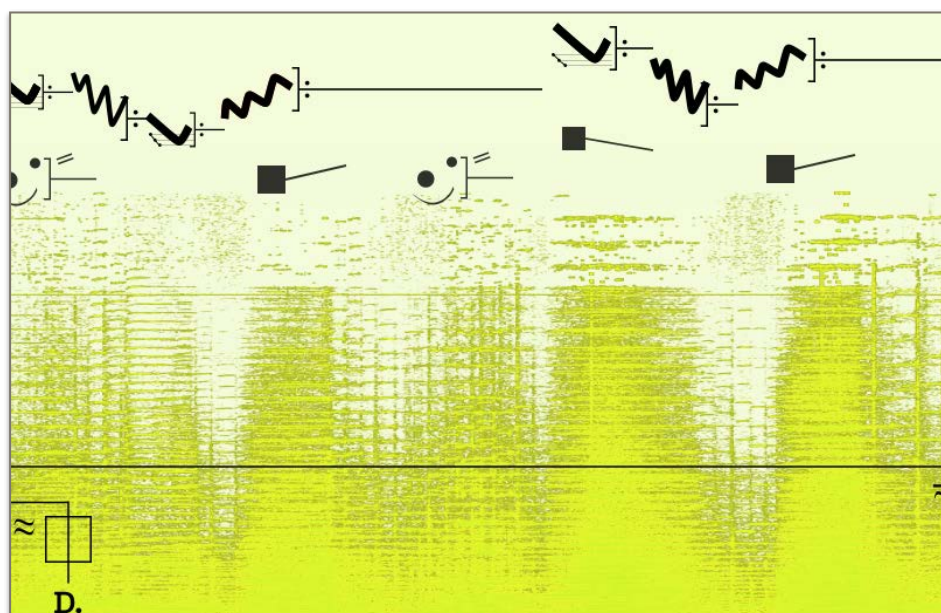

Figure 6.38 - Alberdi 0'46''-0'53'', 14th video <http://bit.ly/2prw7y4><sup>162</sup>

<sup>161</sup> Ibid, page 18, line-staves 1-2.

<sup>162</sup> Ibid, page 18, line-staves 3-4.

The development is significantly shorter than its previous appearances (fig. 6.38).

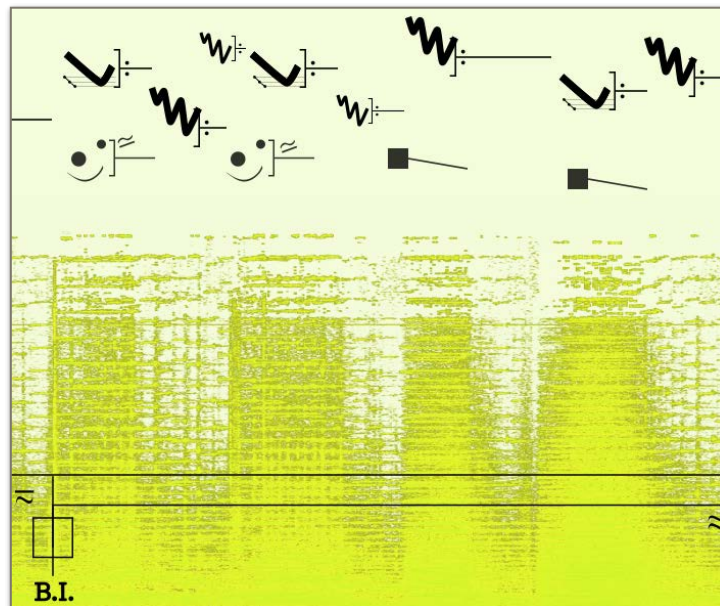

Figure 6.39 - Alberdi 0'54''-1' 01'', 14th video <http://bit.ly/2prw7y4><sup>163</sup>

The B.I. is slightly shortened, as the last fragment is withdrawn (fig. 6.39). The trills are perceived with an oblique pulse, as it forms an intermediary category between the regular pulse and irregular pulse.

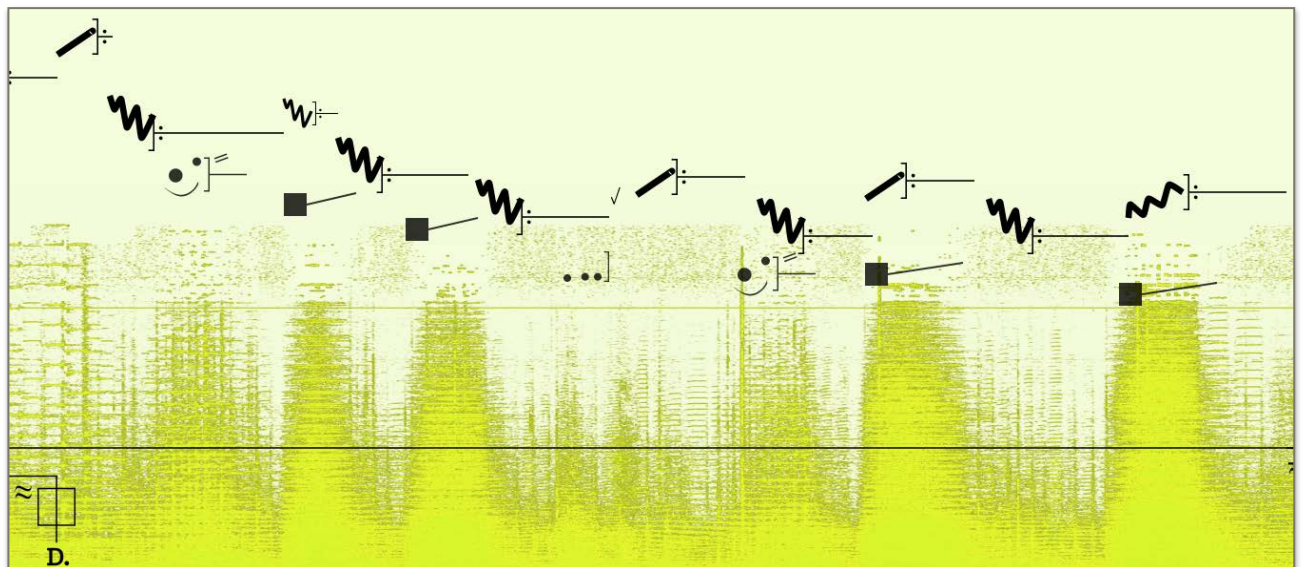

Figure 6.40 - Alberdi 1'01''-1' 13'', 14th video <http://bit.ly/2prw7y4><sup>164</sup>

<sup>163</sup> Ibid, page 18, line-staves 4-5.

<sup>164</sup> Ibid, page 19, line-staves 1-3.

This development is larger in duration compared to the previous, but excludes the use of the first fragment (and its inversion) established by the B.I. (fig. 6.40). It may thus be regarded as a further reduction of motions.

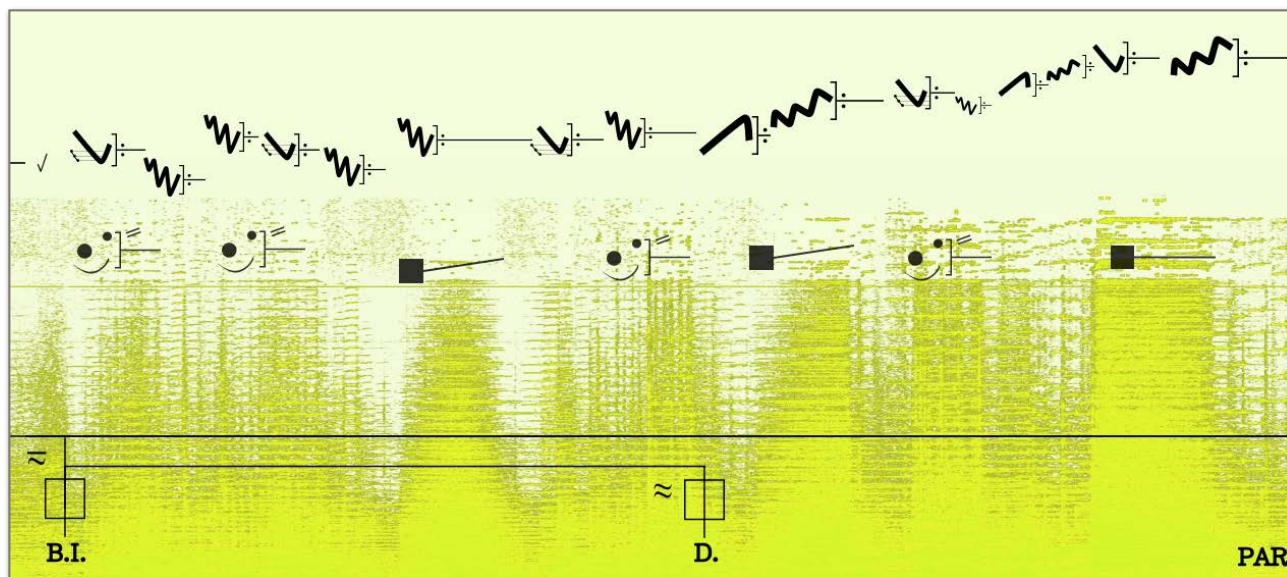

Figure 6.41 - Alberdi 1'14''-1' 26'', 14th video<sup>165</sup>

The example of analysis depicts both elements of B.I. and D., as the duration of both form-elements is shorter than previous establishments (fig. 6.41). The B.I. continues to lack its original last fragment, before a development occurs.

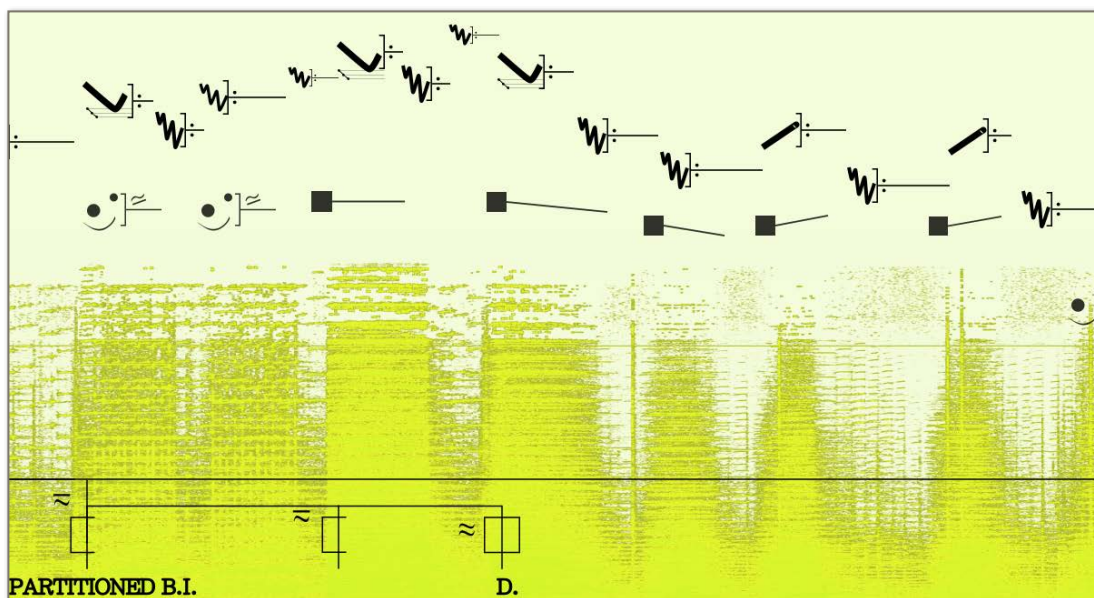

Figure 6.42 - Alberdi 1'26''-1' 38'', 14th video<sup>166</sup>

<sup>165</sup> Ibid, page 19, line-staves 3-5.

<sup>166</sup> Ibid, page 20, line-staves 1-3.



The B.I. is perceived as partitioned, as the fourth fragment in the analysis repeats the previous fragment in a higher register (fig. 6.42). The opening part of the B.I. then reoccurs in a different register, before it further evolves into a new development.

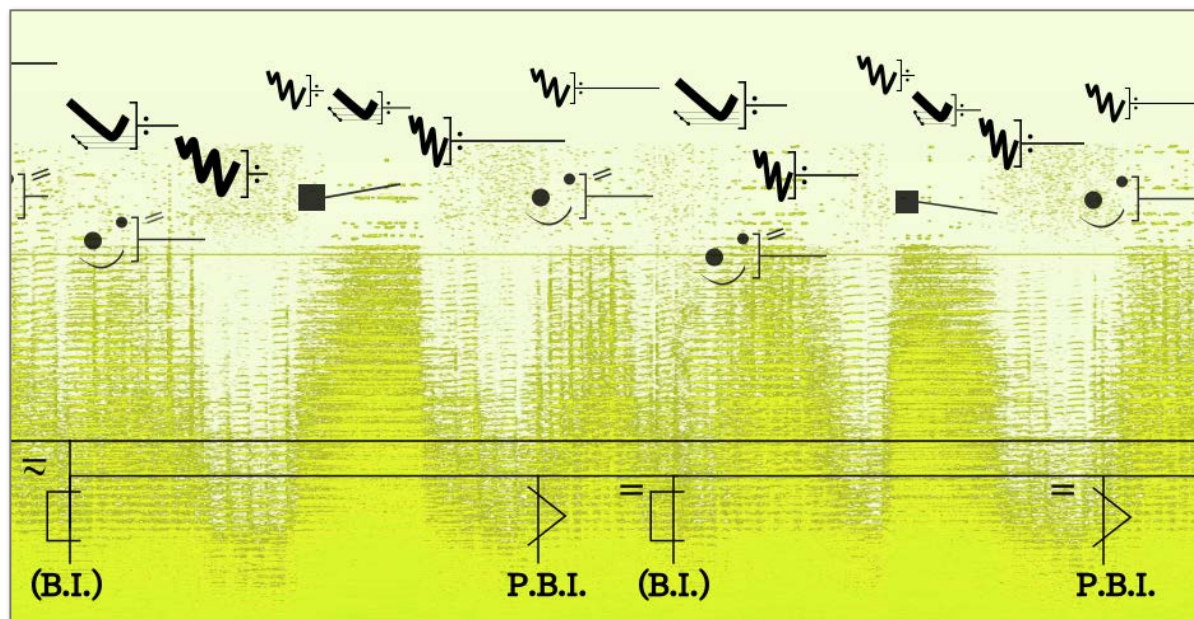

Figure 6.43 - Alberdi 1'38''-1' 47'', 14th video<sup>167</sup>

A seemingly apparent B.I. occurs, but the remaining half is partitioned to one fragment alone (fig. 6.43). The fragment is thus perceived as a reduction of complexity (moderately complex element). These elements are repeated exactly (except for level one-characters).

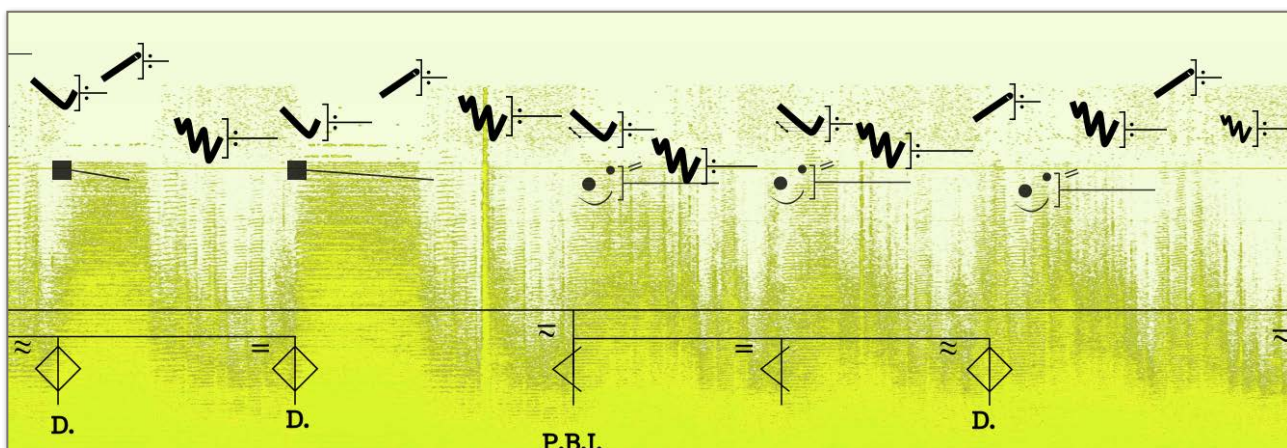

Figure 6.44 - Alberdi 1'47''-1' 59'', 14th video<sup>168</sup>

The development is reduced and perceived as a moderately complex element, then recurred (fig. 6.44). The partitioned first half of the B.I. appears and repeats in similar motions. A new

<sup>167</sup> Ibid, page 20, line-staves 3-4.

<sup>168</sup> Ibid, page 20, fifth staff line - page 21, first staff line.

development occurs with remote similarity, with similar reduced complexity.

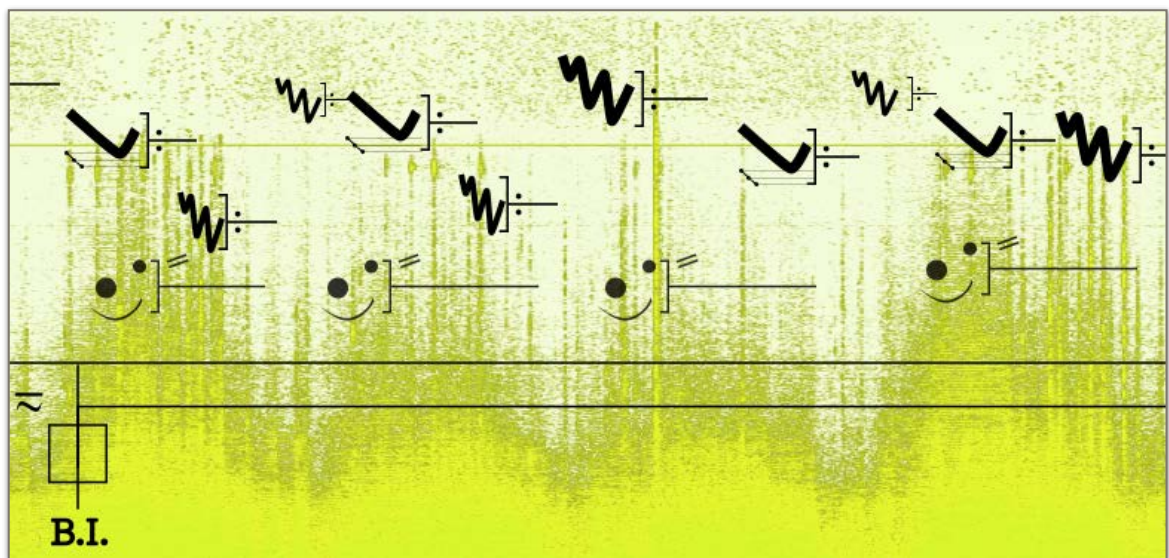

**Figure 6.45 - Alberdi 2'00''-2' 07'', 14th video<sup>169</sup>**

The B.I. occurs in its integral form and could be considered the movement's coda, as this designation differ from the development of partitioned form-elements and refer to the piece's main-theme (fig. 6.45).

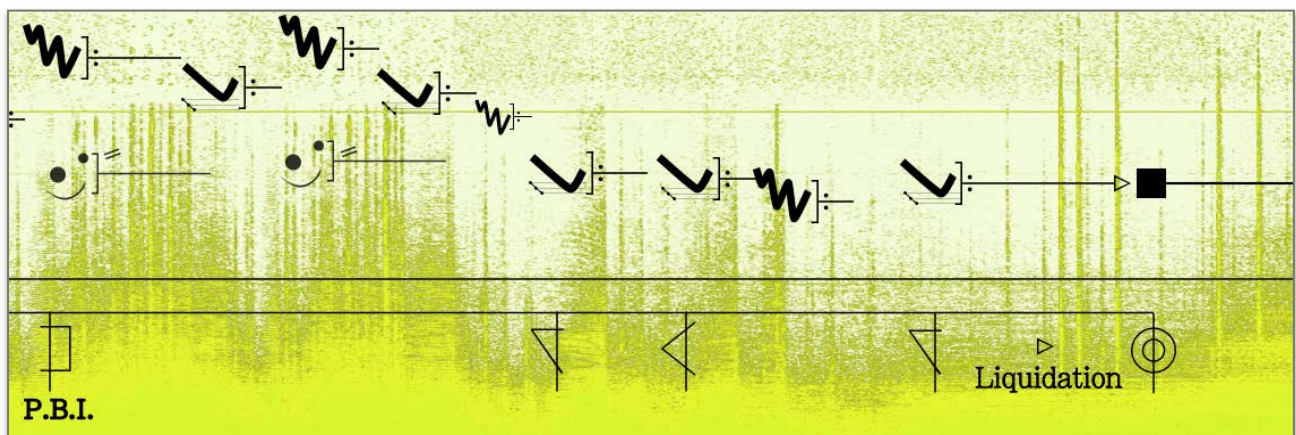

**Figure 6.46 - Alberdi 2'07''-2' 18'', 14th video<sup>170</sup>**

The following sequence is identified by many partitioned occurrences (fig. 6.46). The first representation is the fully partitioned half of the B.I. The second is reduced to only the first fragment of the B.I., and is perceived with relatively simple complexity. The third element is extended to two fragments, before it returns and concludes to the first fragment again. A process of

<sup>169</sup> Ibid, page 21, line-staves 1-3.

<sup>170</sup> Ibid, page 21, line-staves 3-4.

liquidation occurs as the element transforms to a larger complex texture.

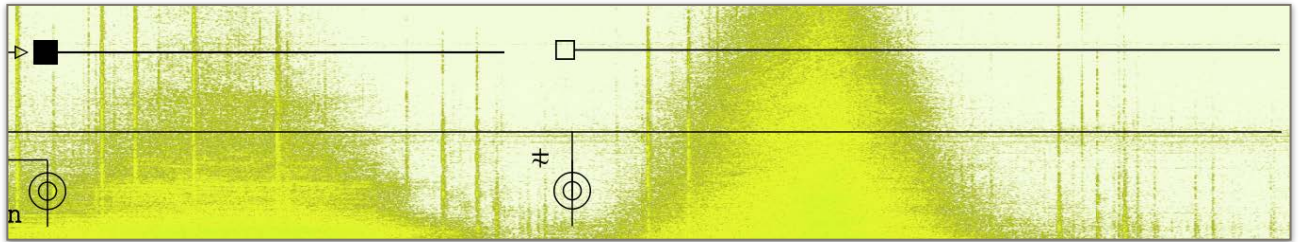

**Figure 6.47 - Alberdi 2'18''-2' 31'', 14th video<sup>171</sup>**

The complex texture departs and an air-sound is presented as an unvoiced complex sound, which is also considered a very simple form-element (fig. 6.47). Therefore, the analysis illustrates a related contrast of the form-building processes. The air-sound marks the end of the sonata's final movement.

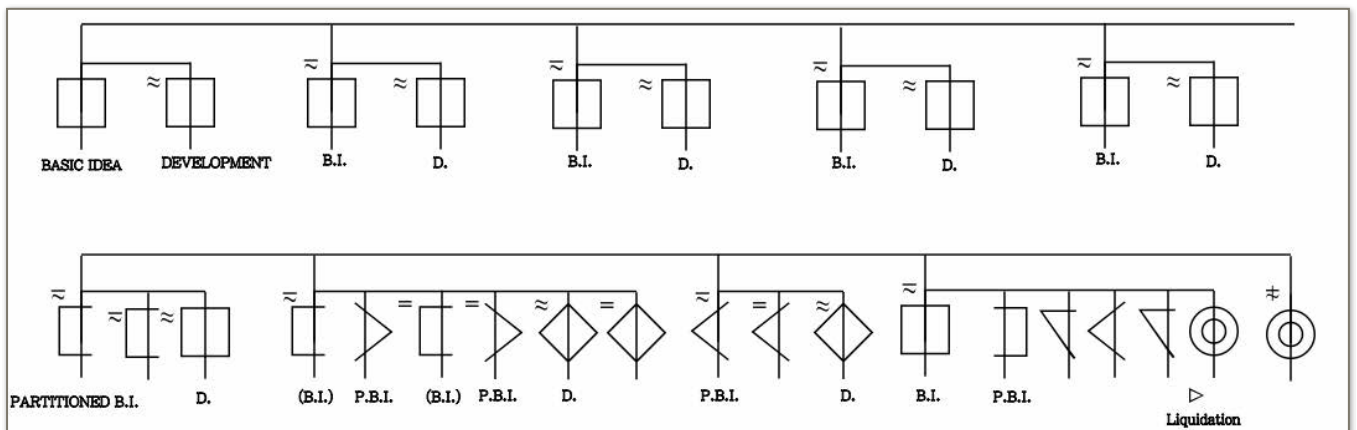
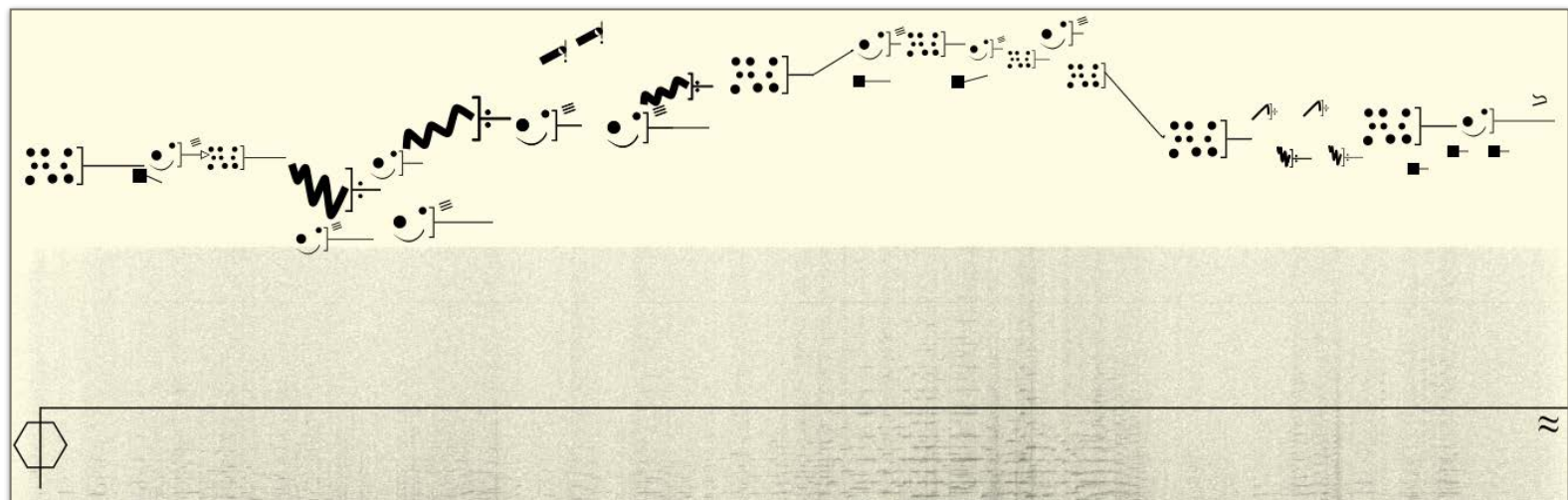

**Figure 6.48 - Alberdi - Collection of form-elements**

The figure (6.48) depicts the collection of form-building elements and processes of this contextual analysis. The main structure may be regarded as an intermediate framework between variation-form and rondo-form, as the material is repeated in discreetly altered forms.

The first line indicates five different relations between the basic idea and an occurring development. The second line indicates five chained motions, where the three-first involve processes of partitioning and reduction of complexity. The second-last chained motion is perceived as a dissolution of the basic idea to the remaining texture, and the last process indicate the air-sound as a separated element.

<sup>171</sup> Ibid, page 21, fourth staff line.



**Figure 6.49 - Lips 15' 25''-15' 52'', 15th video, <http://bit.ly/2prw7y4><sup>172</sup>**

We will now switch to a radically different interpretation; the recorded performance of the man who interpreted it first. Lips' interpretation of the movement is roughly twice as fast as Alberdi's recording and it establishes a character of accumulated sounds rather than a coherent play between melodic fragments (fig. 6.49). However, some melodic fragments are perceived as it emerges through prominent articulation, where the performer plays legato (and not too rapid). Other indications of level one-signs is assigned where sound-patterns are perceived as vague or submerged by its reverberation.

The first form-element is perceived as very complex, as it reflects the extremely asymmetric and irregular lines that is used in an unpredictable manner. The sign for accumulation represents the perceived conflict of irregular sound-objects. The compound-sound objects represent a solitary deviation from accumulation (or supplementary trills). The variable complex-sounds represents cluster glissandi, similar to the previous example of analysis (Alberdi).

The first form-element depicts nine melodic fragments amongst the different variations of accumulated sounds, as it is emphasized in articulation (legato). The transition to the next form-element is perceived with a ritardando, marking the end of the first designation.

---

<sup>172</sup> Ibid, page 16 - page 17.

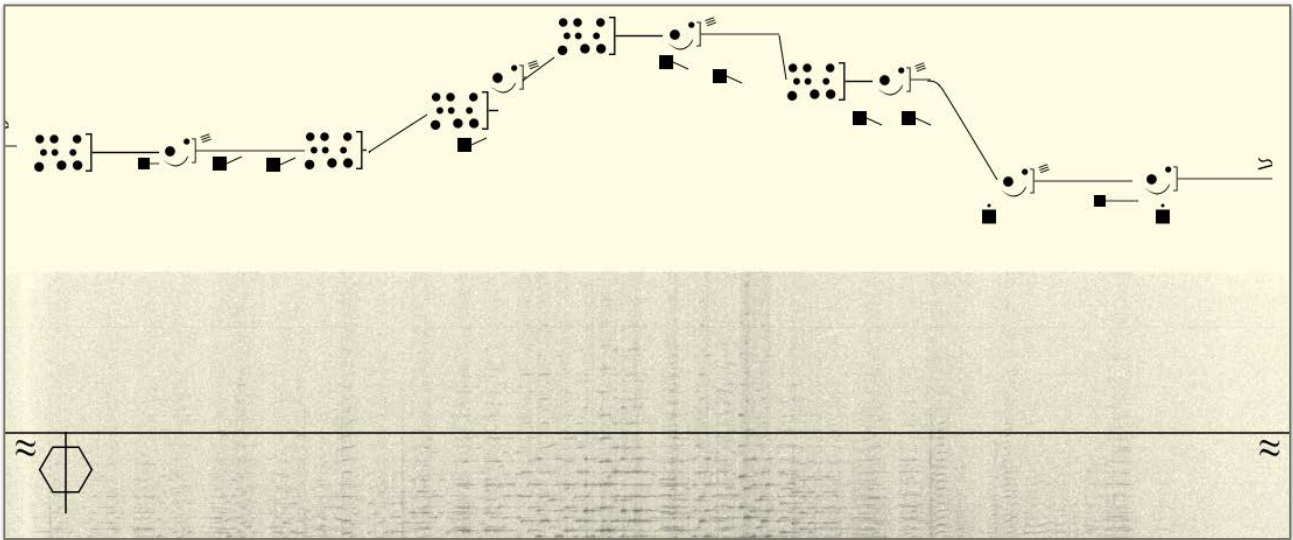

**Figure 6.50 - Lips 15' 52''-16' 13'', 15th video<sup>173</sup>**

The second form-element is perceived with a remote similarity as it is much varied from the previous (fig. 6.50). The music continues to form a dense landscape of sound-patterns, but without a distinct appearance of melodic fragments.

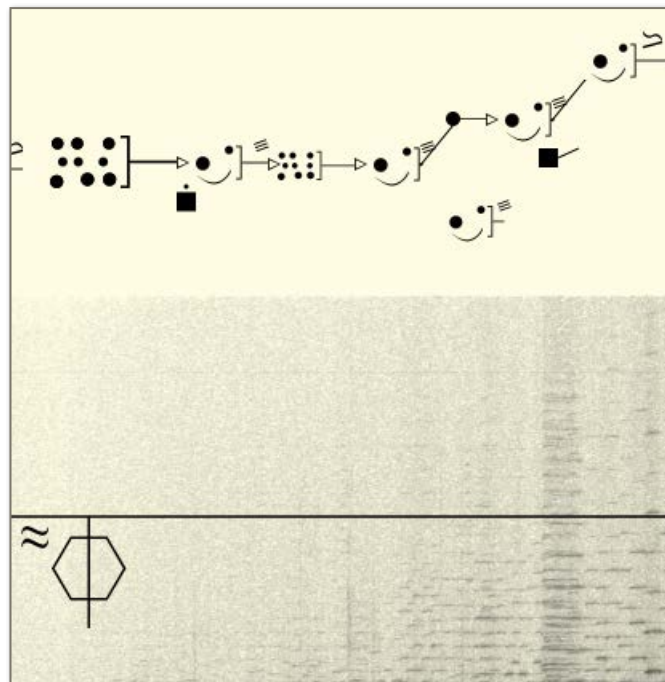
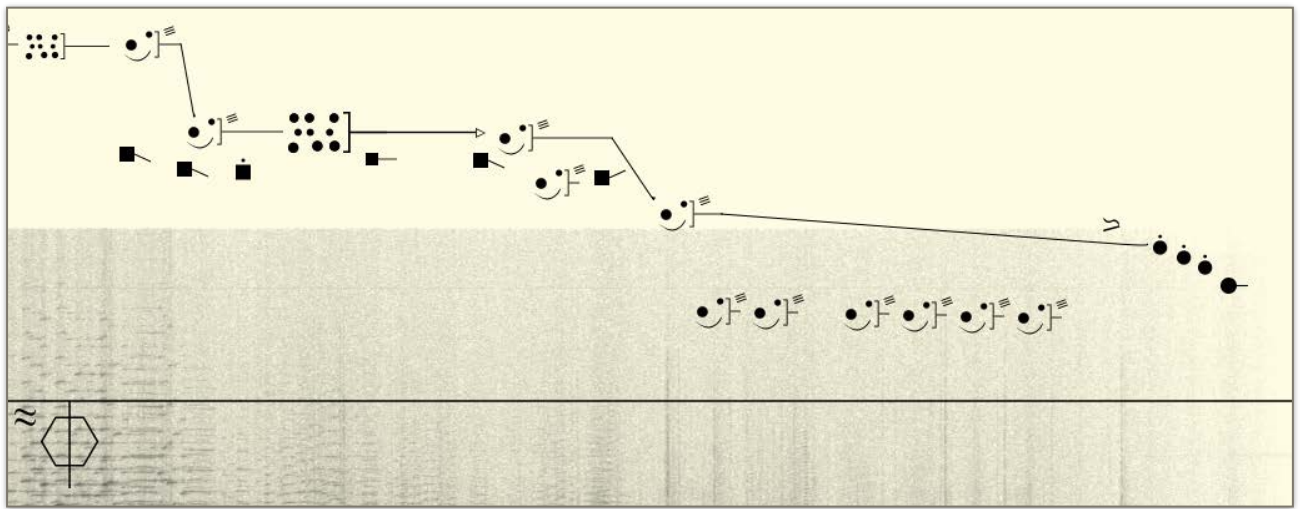

**Figure 6.51 - Lips 16' 13''-16' 21'', 15th video<sup>174</sup>**

The third form-element is significantly shorter than previously established form-elements (fig. 6.51).

<sup>173</sup> Ibid, page 18 - page 19, third staff line.

<sup>174</sup> Ibid, page 19, third staff line-page 20, first staff line.



**Figure 6.52 - Lips 16' 22''-16' 41'', 15th video<sup>175</sup>**

The fourth form-element directs the pattern of sounds towards the lower register (fig. 6.52). The ending is heard as a descending solitary pattern of sounds with recurring low-pitched trills, followed by a declining tempo that results in short impulses and a brief sustained pitch.

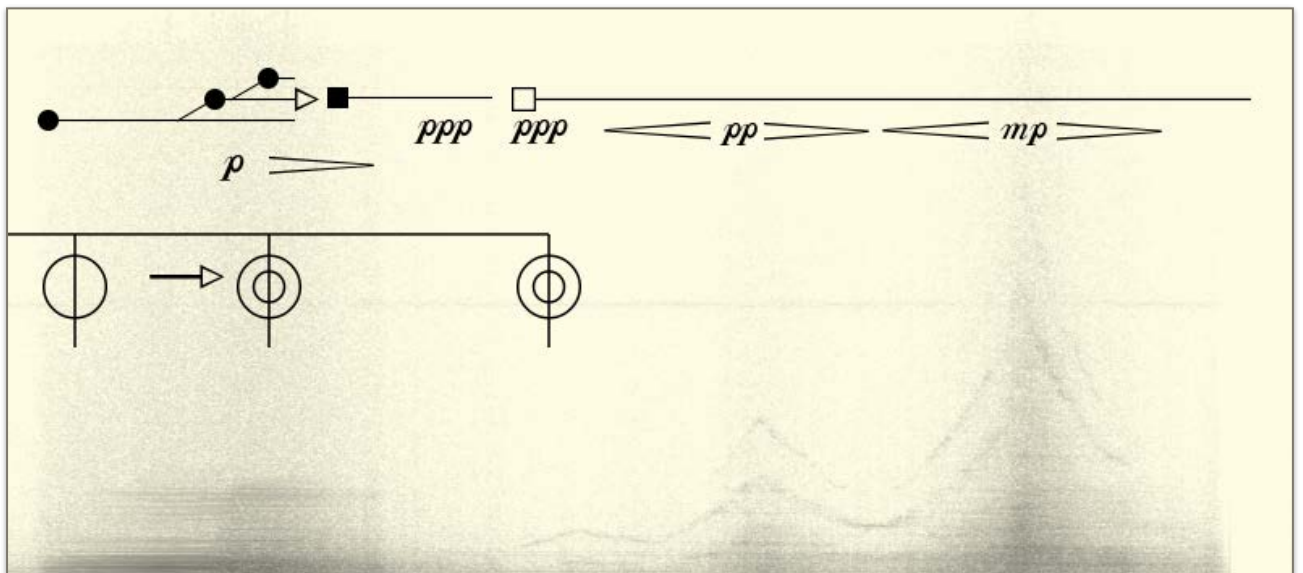
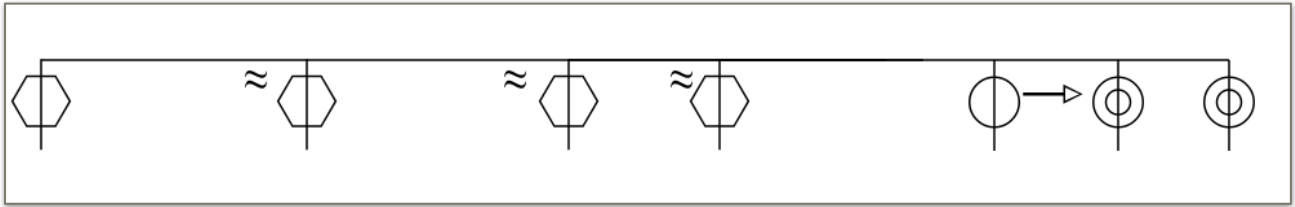

**Figure 6.53 - Lips 16' 42''-16' 57'', 15th video<sup>176</sup>**

The ritardando settles on a long sustained pitch that transforms into a texture (fig. 6.53). The texture quickly decreases in dynamics and merge into reverberated silence. The last form-element of air sound increases quietly from the reverberated silence, and thus may be regarded as related and connected to the motion of form-elements.

<sup>175</sup> Ibid, page 20 - page 21.

<sup>176</sup> Ibid, page 21, fourth staff line.



**Figure 6.54 - Lips - Collection of form-elements**

The figure (6.54) depicts the collection of form-building elements and represents a compressed form-structure compared to Alberdi's interpretation (fig. 6.48). The last textural form-elements is in this context perceived as related and connected (fig. 6.54), unlike Alberdi's performance where they are perceived separately. This similar dimension relates to the analyses of the first and fourth movement, where air-sound were either perceived as an object-field focus or phrase-field focus with the cluster. The consideration on this matter may to some seem peculiar and one could disagree, but my opinion is that the connection with 'silence' between musical elements, especially in this enigmatic style of music, constitute a significant difference of perceiving motions of musical elements.

### 6.9.2 Exosemantic Interpretation - 5th movement - Alberdi versus Lips

<b>Common semantic elements</b>				
<b>Signifier</b>	<b>Semiosis</b>	<b>Signified-&gt;Signifier</b>	<b>Semiosis</b>	<b>Signified</b>
Trills, cells and variable/ stable clusters (L <sub>1</sub> )	CMPAR +INFER (F <sub>1</sub> )	Incidents	CONNOT (F <sub>2</sub> )	Passing lights
Melodic fragments perceived with articulate legato (L <sub>2</sub> )	CMPAR +CONNOT (F <sub>1</sub> )	Softness	CONNOT (F <sub>1</sub> )	Soothing
Closing melodic pattern to larger cluster (L <sub>2</sub> )	CMPAR +INFER (F <sub>1</sub> )	Coagulation	CONNOT (F <sub>2</sub> )	Rest
<b>Iñaki Alberdi</b>				
Emphasized focus of sound-patterns, slower tempo and relative complex form-elements (L <sub>2</sub> )+(L <sub>3</sub> )	CMPAR (F <sub>2</sub> )	Breeze	CONNOT (F <sub>0</sub> )	A succession of images passing through the mind during sleep
<b>Friedrich Lips</b>				
Emphasized focus of sound-objects, faster tempo and very complex form- elements (L <sub>1</sub> )+(L <sub>2</sub> )+(L <sub>3</sub> )	CMPAR (F <sub>2</sub> )	Vigorous wind	CONNOT (F <sub>0</sub> )	A terrifying dream in which the dreamer experiences feeling of helplessness

# 7 Critical Reflections

This chapter intends to reflect on the attainments that this thesis has provided, and what it has not, with a critical consideration of the apprehended material.

## 7.1 Introduction

This thesis developed from a concern with the degree to which distinct sonic and structural aspects are drawn from the perception of music-as-heard, and how these elements occur from recorded performances. The specific focal point of my inquiry was the explorations of emerging gestalts through performances and interpretations of the selected works by Gubaidulina. This was due to my ambition to explore musical dimensions as heard, to illuminate a certain knowledge that would not be attained by a traditional analysis of the score. However, the obtained insight through the use of aural sonology is limited to its designated purpose, which is the categorization of sound and sound-patterns in to three levels of articulations.

First I intend to present a summary of my research regarding the extensive analysis of *De Profundis*, and a reflection of the compared interpretations by performers in examples of *Et Exspecto*.

## 7.2 Summary of my research

The timbral transfigurations of sounds and sound-patterns in *De Profundis* are an important characteristic of endosemantic relations in the music and exosemantic representation of symbolic metaphors. The transfigurations are expressed in directions between dichotomies of sound-objects ( $L_1$ ), such as the lowest sonorities to the highest ( $\bullet \text{---} \triangleright \bullet \text{---}$ ), the iterated energy articulation to the sustained ( $\blacksquare \text{---} \triangleright \blacksquare \text{---}$ ), the stable sound spectrum to the variable ( $\blacksquare \text{---} \triangleright \blacksquare \text{---}$ ), the clustered pitches to the 'unvoiced' textures ( $\blacksquare \text{---} \triangleright \square \text{---}$ ) and the unified sound-objects to monophony ( $\bullet \text{---} \triangleright \bullet \text{---}$ ).

The harmonic transfiguration ( $L_2$ ) from complexity to consonance ( $\blacksquare \text{---} \triangleright \blacksquare \text{---}$ ), seems to characterize the musical structure as a whole; the transformation is established through the first form-field, which connects exosemantic associations of 'depths' and 'sinfulness' to 'morning' and 'hope'. The second form-field is perceived as a transformation from dissonance to further complex sound-textures, with a sudden change to consonance at its very end, which connects exosemantic associations of 'pain' and 'struggle for redemption'. The third form-field is perceived with monophony and a lack of harmonicity that ends with a conflict of consonant and complex textures, where consonance triumphs as a remaining harmony, which further connects exosemantic associations of 'waiting', 'praying', and finally, 'forgiveness'.



The transfiguration of frequent, increasing dynamic forms ( $L_3$ ), is perceived as a connected structure through the performance of Geir Draugsvoll, which connects exosemantic associations of transforming from 'the depths' to 'the heavenly'. The interpretation seems to fit the descriptive subtitle of Psalm 130 by "New International Version"; *A song of ascents*.<sup>177</sup>

Dichotomy plays an equally significant role in the analyses of *Et Exspecto*, but in the three-first movements, sound-elements are perceived opposed and separated towards each other and less as a transfiguration of timbre. The play between these separated dichotomies are identified through the first movement as clusters and chords ( $\blacksquare \text{---} + \text{⋮} \text{---}$ ) versus the unvoiced texture ( $\square \text{---}$ ), the dissonant chorale ( $\text{⋮} \text{---}$ ) versus the iterated tritone ( $\text{⋮} \text{---}$ ). Opposed dichotomy in the second movement is identified as the monophonic, chromatic melody ( $\bullet \text{---}$ ) versus the consonant chorale ( $\text{⋮} \text{---}$ ). In the third movement, dichotomy is identified as the iterated complex texture ( $\blacksquare \text{---}$ ) versus the sustained glissandi ( $\blacksquare \text{---}$ ).

The fourth movement however, consists of an extended transformation of a chorale ( $\text{⋮} \text{---}$ ) to the culmination of alternating clusters ( $\blacksquare \text{---}$ ). The sound-objects in the fifth movement is identified either as continuous melodic fragments with ornaments ( $\bullet \text{---}$ ) or as an accumulation of sounds ( $\text{⋮} \text{⋮} \text{⋮}$ ) that results in an unvoiced sound object ( $\square \text{---}$ ).

The different interpretations by the performers showed to a large extent the different possibilities of interpreting the material, as seen in the aural analysis. Still, the listener seemed to be left with a certain general character of interpretation-strategies by all performers. *The unités sémiotiques temporelles* present a description of kinetic anaphones with a potential for organizing a musical discourse, as an effort to apprehend elements of musical endosemantics.<sup>178</sup> These categories seem relevant to apply to these general characters of interpretation-strategies.

The interpretation of my performance was characterized by indistinct energy articulations, which established a reticent character. An exosemantic interpretation of this character, could be 'drifting', where a description of this is 'an image of a boat that, having lowered its sails or stopped its motor, continues to drift thanks to its acquired speed'.<sup>179</sup>

However, Alberdi's performance was characterized by distinct energy articulations, which could be interpreted exosemantically as something that is 'trying to start'. A description of this

---

<sup>177</sup> *Holy Bible*, New International Version®, <https://www.biblegateway.com/passage/?search=Psalm+130> (22/04/17).

<sup>178</sup> Thoresen, 307.

<sup>179</sup> *Unités sémiotiques temporelles* quoted in Thoresen, 307-309.

semantic aspect, is 'as if something is trying to get on its way'.<sup>180</sup>

Draugsvoll's interpretation of the selected examples was characterized with an often increase in tendencies of musical elements, which could be interpreted exosemantically as a 'protraction', which is described as 'stretching under tension, creating a feeling of expectation'.<sup>181</sup>

Friedrich Lips' performance was characterized by a faster tempo and pulse, which in this context could be interpreted exosemantically as 'heaviness', that associates with 'the impression of a difficulty to be overcome, one that bars an energy insisting on moving ahead'.<sup>182</sup>

These expressive characters of semantic elements, emerging through the performers interpretation of *Et Exspecto*, could indicate a connection to different aesthetics and traditions.

### 7.3 Expanding sonology

In this process, I have acquired the use of the sonological method, which requires a comprehension of the coherent framework established by Thoresen and further apply these ideas in new contexts. The endeavour of expanding these concepts can be considered in three parts:

#### 1) Established signs in new contexts

Parts of the illustrated analyses represents established signs from sonology that constitutes a different purpose or use than its original intentions, such as:

- Signs of spectromorphology situated in parenthesis constitutes the framework of occurring sound-objects (L1), rather than an extensive level one-analysis. In this context, these illustrated sound-characters depicts the distinct relations between iterated and sustained energy, as well as pitched and complex sounds in the music of Gubaidulina.<sup>183</sup>

- Vertical lines across the prolongation line (showing sustained articulation in *Et Exspecto*, 1st movement), represents a recurrence or change of pitch that does not interfere with the perceived character of the sound-object (L1). In segments where musical elements are sustained extendedly in time, these short vertical lines may facilitate the apprehension of recurrences or changes.<sup>184</sup>

---

<sup>180</sup> Ibid.

<sup>181</sup> Ibid.

<sup>182</sup> Ibid.

<sup>183</sup> Applied in the analysis of *De Profundis*.

<sup>184</sup> Applied in the analysis of *Et Exspecto*, 1st movement.

- Depictions of the increasing dynamic tendencies are applied to illustrate the emerging tension between sound-objects and textures even though they are separated by significant silences.<sup>185</sup>

## **2) Parts of Aural Sonology that has not yet been used**

The semiotic-model for exosemantic interpretation has not yet been used in artistic research, other than the author himself. Furthermore, I am the first person to execute an exosemantic comparison of different interpretations through the semiotic model.

## **3) New developments of signs**

I have attempted to develop new signs to illustrate distinct relations of sound-patterns (L<sub>2</sub>), that seems relevant to the selected works by Gubaidulina.

The first model is the considerations of harmonic color, and how these textural transfigurations emerge between consonance, dissonance and complex harmonicity.

The second model is the considerations of melodic fragments, and how sound-patterns could be perceived as separate gestures throughout a continuous motion.

## **7.4 Intension of this artistic research**

My main concern of this thesis is to apply a tool that provides, to some extent, clarity to the interpretation done by the performer. This method will prove to be helpful for performers that are studying the works, in order to listen and explore established interpretations, or even their own recorded performances. By getting acquainted to reductive- and taxonomic listening, the music may be approached with a useful expedient providing the performer with a different perspective of reflection.

## **7.5 A look in to other publications**

Although this project involves a partial consideration of symbolic interpretation, it certainly is limited to the reconstruction created by the applied methods of aural sonology. A more traditional analysis of the music with the focus of pitch would provide other contents of symbolic indications to my research. In *De Profundis*, one may observe how the pitch moves from the deepest register towards the highest, which may conventionally be interpreted as 'out of the depths' towards 'heaven'. Other musical symbolism may be acquired in regard to *De Profundis*, such as the chorale reference founded on baroque rhetoric that may establish an association to the Christian belief system and to

---

<sup>185</sup> Applied in the analysis of *De Profundis* and *Et Exspecto*, 4th movement.

Johan Sebastian Bach, which Gubaidulina was greatly inspired of, as he also dedicated his entire work to God.<sup>186</sup> By interpreting the chorale and the development of pitch, one may find images that confront associations of human being and the earth, with heavenly and divine.

In an essay by Julie Hirzbergerová named 'Because it is breathing!', a further discourse on symbolism in Gubaidulina's music is situated. The work *Seven Words* for violoncello, accordion and strings from the year 1982 centers on the theme of the crucifixion of Jesus Christ, as it is a reference to his seven last words on the cross.<sup>187</sup> Because of its time during the former Soviet Union, the title was printed under the neutral name *Sonata*.<sup>188</sup>

The composer uses different symbolic metaphors on various levels in this work, such as musical and graphic symbolism.

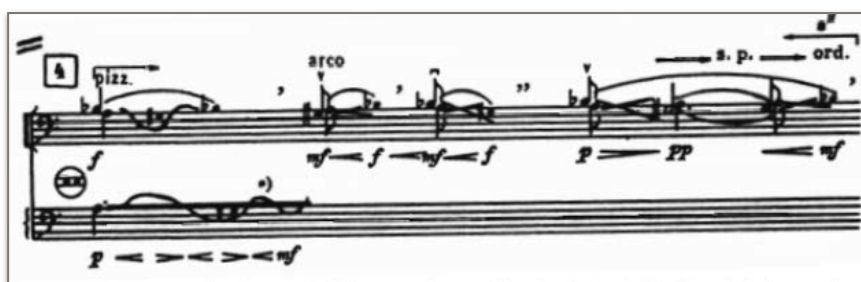

**Figure 7.1 - Score Excerpt, *Sieben Worte***

The standing axe of the cross is seen horizontally through the directions orbiting the note A, either going upwards or downwards, always returning to the A note, forming the crossing axe.

In the scholar publication "Musical contents and symbolic interpretation in Sofia Guabaidulina's *Two Paths: A dedication to Mary and Martha*", Young-Mi Lee illustrates how the cross is interpreted through melodic motions:

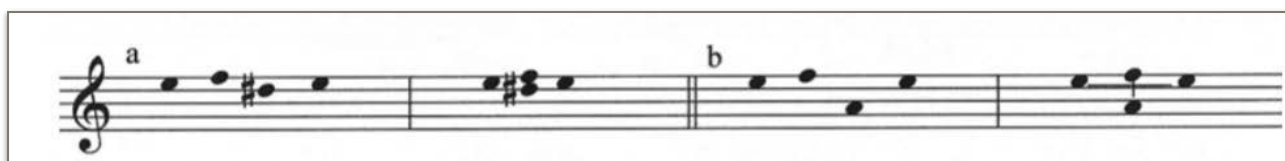

**Figure 7.2 - Two occurrences of the melodic cross<sup>189</sup>**

<sup>186</sup> The inspiration of Bach can easily be recognized, as Gubaidulina wrote a string quartet in 2002 with the title *Reflections on the theme B-A-C-H*.

<sup>187</sup> The words can be found in the first four books of the new testament according to St. Marcus, St. Matthew, St. Lucas and St. John.

<sup>188</sup> Julie Hirzbergerová, "Because it is breathing! The accordion in the music on sacred themes" (Austria), 4.

<sup>189</sup> Lee, *Musical contents and symbolic interpretation in Sofia Guabaidulina's Two Paths: A dedication to Mary and Martha*, 60.

The first example (a) (fig. 7.2) illustrates a similar melodic motion as the excerpt of seven words (fig. 7.1). The second example (b) illustrates how a longer interval may represent the standing axe of the cross. Lee argues that the symbol of the cross appears in several of Gubaidulina's works.<sup>190</sup> In *De Profundis*, these melodic cross-motifs could be assigned to parts of the chorale:

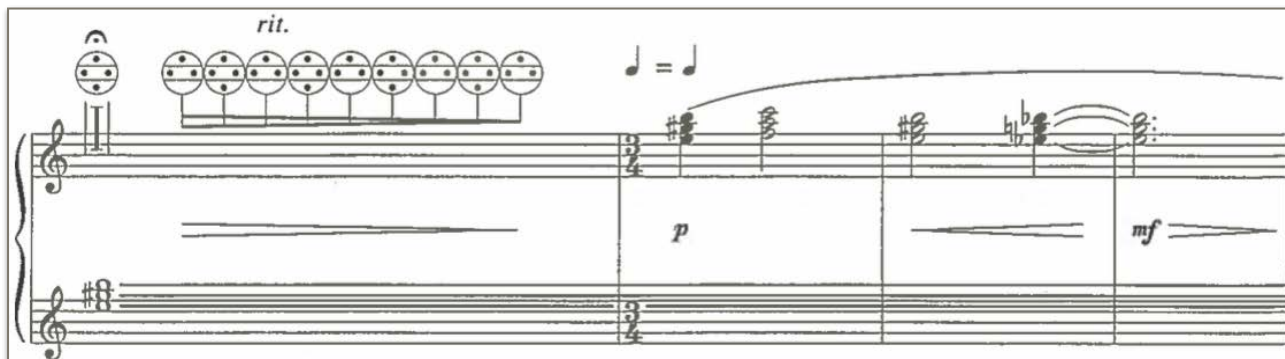

**Figure 7.3 - Score excerpt, *De Profundis*<sup>191</sup>**

The melodic cross is identified at the second half of the bar line, as a chromatic motion of major-chords (fig. 7.3).

Further claimed representations of symbolism in *Sieben Worte* is the holy Trinity, where the accordion represents God the Father, cello the Son-Jesus on the cross, and strings the Holy Spirit.<sup>192</sup> Hirzbergerová further describes times where both solo instruments fuse into one voice, creating an emphatic monologue, which is completed by the strings playing the role of the narrator, the Evangelist.



**Figure 7.4 - Score excerpt, *Sieben Worte***

<sup>190</sup> Ibid, 57.

<sup>191</sup> Gubaidulina, *De profundis*, page 12, fourth staff line.

<sup>192</sup> Hirzbergerová, "Because it is breathing! The accordion in the music on sacred themes" (Austria), 4.

A visible representation of the cross is seen in the score (fig. 7.4).

Gubaidulina indicates her use of symbolic elements in the program note of the work "Two Paths: Music for Two Solo Violas and Symphony Orchestra":

Naturally, music doesn't convey these metaphysical stimuli to us literally and directly. That isn't its job. It is, however, capable of creating a metaphor, a kind of comparison concealed from the concrete. For example, sounds moving in different directions, motion upwards or downwards, already can constitute a sufficiently definable metaphor of two differing psychological directions, two paths into the unknown forest of the perpetual variety of life.<sup>193</sup>

Still, my attempt to interpret exosemantic metaphors within a critical consideration of musical perception, rely on the context of which the semantic elements are associated. A common association is that the clusters are intense, evil or sinful opposed to its dichotomy, major-chords, which often is associated with 'rest', 'good' or 'forgiving'.

If these semantic elements should be interpreted in a different context, for instance, during World War II in Europe, they may signify a complete different association. The persistent use of non-Jewish Western classical music initiated by the Nazis, such as Beethoven, Wagner and Anton Bruckner, created a new context where major-harmonies, heroic and triumphal rhythm and musical characters, were to many associated with fear, marching soldiers and the death of millions. However, serialism as a style directed to the intellect of the listener; it was deprived of the emotional values that traditional classical music conveyed, such as the lack of 'beautiful' melodies, major-chords and designated rhythms. Set in this context, a cluster could be interpreted as 'good' and 'hope', and the structure of spiritual symbolism in Gubaidulina would be reversed.

On a further look upon the artistic research of Lee, the publication bases its research on a detailed analysis of the score:

Gubaidulina achieves a remarkable timbral transformation in variation V. The tutti, the undulating chordal motion by vibraphone, sustained celesta, and muted viola, represents a shimmering celestial image. Crotales, chimes, and tam-tam add diverse metallic tone colors to

---

<sup>193</sup> Gubaidulina quoted in Young-Mi Lee, *Musical contents and symbolic interpretation in Sofia Gubaidulina's 'Two Paths: A dedication to Mary and Martha'*, 4.

this surreal resonance. The three-time entrances of the other strings, also muted and contoured by a crescendo-decrescendo fragment, magnify the expressive timbral richness in the passage.<sup>194</sup>

The quotation, which is situated out of its context, describes both endosemantic relations in the music (such as 'timbral transformation', 'sustained notes') and exosemantic associations ('remarkable', 'surreal'). My concerns with associating the musical elements with entities beyond its own material is that it is not implied in the music itself.

## 7.6 Last words

My theoretical approach does not include this departure of analysis and interpretation as seen in the publications of Lee and Hirzbergerová, both in terms of emphasis of pitch-structures closely related to compositional style and historic references. These are obvious symbolic elements intrinsic to the composition, that somewhat lacks in my analysis and interpretation of illuminating symbolism. An extensive analysis including these reflections could be fruitful, especially the explorations of spiritual dimension that relates to the compositional style.

An illustration of perceived pitch and use of register was withdrawn from my analysis of *De Profundis*, as I felt other semantic elements expressed a similar indication of exosemantic symbolism. Furthermore, an exosemantic interpretation of symbolic notation in the score is also neglected in my thesis, along with other metaphysical symbols, such as the image of the open bellow of the accordion, which could be associated with the symbol of 'the rib of Christ', or the performers exhaustive effort of performing physical demanding parts of the piece, that could symbolize the pain for redemption. These symbolic metaphors belong to a semiosis of open interpretation, or it is 'justified' as a stated reference indicated by the composer. I argue that these indications belong to an external dimension of the music as heard.

However, these dimensions do not provide much insight to me as a performer, as it does not provide any details concerning the interpretation behind the performance. The comprehensive study of performance practice is important, not exclusively for the benefit of other practitioners, but also for music-historians and musicologists that searches a deeper understanding of the performers role in the music. In traditional analyses, musical qualities seem to manifest itself as a written score and do not provide an understanding of how these qualities emerge through interpretations of the sounding music. This knowledge is crucial in order to comprehend aesthetics in present time of different traditions and cultures.

---

<sup>194</sup> Ibid, 39.

I argue that the aural analysis provides a larger understanding of sonic and structural aspects that a traditional analysis of the score could not. The visual aesthetics of the sonology analysis is an important factor, that provides the analyst a visual understanding of the structural framework of gestalts in a sounding musical work. Even though the knowledge is limited to the designated methods of sonology, and other elements intrinsic to the composition itself could be left out, each approach should not necessarily exclude the other. In future research, aural analysis could be combined with a traditional analysis of the composition, in order to point out sounding functions and gestalts of the music and the interpretation as heard.



# Bibliography

Askew, Caroline M. «Sources of inspiration in the music of Sofia Gubaidulina: Compositional aesthetics and procedures». University of Huddersfield, 2002..

Cramer, Alfred. *Musicians & composers of the 20th century*. Gubaidulina-Sofia. Salem press, 2009.

Encyclopedia Britannica, s.v. "causal inference".  
<https://www.britannica.com/topic/causal-inference> (06.05.2017)

Friedrich, Kevin. «Interview of Friedrich Lips». *Accordions Worldwide*, 1999. <http://www.accordions.com/interviews/lips/lips2.shtml> (07.05.17)

Greek Orthodox Archdiocese of America. "The Nicene Creed",  
<https://www.goarch.org/-/the-nicene-creed> (30/4/17).

Gubaidulina, Sofia. *De Profundis*. 1978. Karthause-Schmülling Musikverlag,

—.. *Sieben Worte für Violoncello, Bajan und Streicher*. 1982. Sikorski.

—. *Sonate: Et Exspecto*. 1985. Musikverlag Ulrich Schmülling.

Holy Bible, New International Version.  
<https://www.biblegateway.com/passage/?search=Psalm+130> (22/04/17)

Kurtz, Michael. *Sofia Gubaidulina*, translated by Christoph K. Lohmann. Indiana University, 2007.

Lee, Young-Mi. *Musical contents and symbolic interpretation in Sofia Gubaidulina's Two Paths: a dedication to Mary and Martha*. Phd. School of The Ohio State University, 2007.  
[https://etd.ohiolink.edu/pg\\_10?0::NO:10:P10\\_ACCESSION\\_NUM:osu1185466134](https://etd.ohiolink.edu/pg_10?0::NO:10:P10_ACCESSION_NUM:osu1185466134) (11.05.17).

Lips, Friedrich. *The Art of Bayan Playing*. Edited by Ulrich Schmülling. Karthause Schmülling Publications, 1991.

Lukomsky, Vera. "The Eucharist in my fantasy: Interview with Sofia Gubaidulina". *Tempo* 206, 1998. [https://www.jstor.org/stable/945505?seq=1#page\\_scan\\_tab\\_contents](https://www.jstor.org/stable/945505?seq=1#page_scan_tab_contents)

McComb, Todd M. "What is monophony, polyphony, homophony, monody etc.?", *Medieval Music & Arts Foundation*, <http://www.medieval.org/emfaq/misc/homophony.html> (28.03.17)

Medić, Ivana. «Gubaidulina, misunderstood». The Open University United Kingdom, 2012. <http://www.doiserbia.nb.rs/img/doi/1450-9814/2012/1450-98141200014M.pdf> (11.05.17).

Music For Accordion. "Bio: Fredrich Lips". <http://www.musicforaccordion.com/boutique/inform/lips/lips.htm> (5/4/17)

Orthodox Church in America. "The Nicene Creed", <https://oca.org/orthodoxy/the-orthodox-faith/doctrine-scripture/the-symbol-of-faith/nicene-creed> (30/4/17).

Oxford Dictionary of English, s.v. "endo", <https://en.oxforddictionaries.com/definition/us/endo-> (15.03.17).

Pro arte international mangement. "CV: Geir Draugsvoll". <http://www.proarte.no/dra/draugsvoll.htm> (10.05.17).

Schmelz, Peter J. «Review of Sofia Gubaidulina». *Notes*. Second Series(Vol. 65, No. 1), 2008.

Smith, David Woodruff. "Phenomenology". Edition by Edward N. Zalta . The Stanford Encyclopedia of Philosophy, 2016. <https://plato.stanford.edu/archives/win2016/entries/phenomenology/>.

*The Academy of Natural Sciences of Drexel University. "Butterfly Life Cycle"*. <http://www.ansp.org/explore/online-exhibits/butterflies/lifecycle/> (14/03/17).

Thoresen, Lasse. «Exosemantic Analysis of music-as-heard, Meaning and Meaningfulness in Electroacoustic Music». Electroacoustic music studies network, 2012. [http://www.ems-network.org/IMG/pdf\\_EMS12\\_thoresen.pdf](http://www.ems-network.org/IMG/pdf_EMS12_thoresen.pdf) (05.04.17)

—. *Emergent Musical Forms: Aural Explorations*. Studies in Music of the University of Western Ontario, 2015.

Vera Lukomsky. "Sofia Gubaidulina: "My Desire is Always to Rebel, To Swim Against the Stream!" *Perspectives of New Music*, 1998. [https://www.jstor.org/stable/833574?seq=1#page\\_scan\\_tab\\_contents](https://www.jstor.org/stable/833574?seq=1#page_scan_tab_contents)

## Discography

Alberdi, Iñaki. Komp Sofia Gubaidulina. "Et Exspecto". *Gubaidulina: Kadenza*. EtCetera-Records, 2011.

Angell, Andreas. Komp. Sofia Gubaidulina. "Et Exspecto". Unpublished, Norwegian Academy of Music, 2015.

Draugsvoll, Geir. Komp. Sofia Gubaidulina. *Silenzio / De profundis / Et exspecto / In Erwartung*. BIS Records, 1995.

Lips, Friedrich. Komp. Sofia Gubaidulina. *ET EXSPECTO*. Classical Accordion CD, 1992.

# Appendices

Link to videos of aural analyses: <http://bit.ly/2prw7y4>

A CD with the following videos is added with the physical copies of the thesis, located in the library of the Norwegian Academy of Music.

- Video 1 : Geir Draugsvoll. *De Profundis*.
- Video 2: Iñaki Alberdi. *Et Exspecto* (1st movement).
- Video 3: Andreas Angell. *Et Exspecto* (1st movement).
- Video 4: Geir Draugsvoll. *Et Exspecto* (1st movement).
- Video 5: Friedrich Lips. *Et Exspecto* (1st movement).
- Video 6: Andreas Angell. *Et Exspecto* (2nd movement).
- Video 7: Iñaki Alberdi. *Et Exspecto* (2nd movement).
- Video 8: Geir Draugsvoll. *Et Exspecto* (3rd movement).
- Video 9: Friedrich Lips. *Et Exspecto* (3rd movement).
- Video 10: Andreas Angell. *Et Exspecto* (4rd movement).
- Video 11: Friedrich Lips. *Et Exspecto* (4rd movement)
- Video 12: Geir Draugsvoll. *Et Exspecto* (4rd movement)
- Video 13: Friedrich Lips. *Et Exspecto* (4rd movement)
- Video 14: Iñaki Alberdi. *Et Exspecto* (5th movement)
- Video 15: Friedrich Lips. *Et Exspecto* (5th movement)